

DPM Series Application

Bimba Digital Panel Meter Model DPM Application Example



The DPM controller is ideal for measuring and gauging applications. The measurement repeatability, when combined with the PFC, is 0.001 inch per inch of stroke. The DPM supplies the PFC with a very accurate excitation voltage and has a 16 bit A/D converter. The DPM/PFC combination can be used as a Go/No Go gauge for in process quality control, among other things. A typical application follows:

Desired Result: In line process control verification to determine if parts meet required specifications.

Example One

The DPM is used in conjunction with a PFC cylinder to verify part specifications during an assembly process, ensuring quality of parts. RS-485 communications are used to monitor the PFC displacement remotely from the DPM. (The RS-485 protocol allows up to 32 devices to be connected to one port, and is less susceptible to signal noise since the analog to digital conversion is done in the DPM controller, utilizing the same power supply and ground planes as the PFC.) This information will be read by a PLC. The PLC determines what should be done to the part based on the displacement values read. (i.e., Send part on to the next process, or divert to rework station.) Use the DPM/PFC combination to verify if nuts are present and tightened correctly by checking the height of the nut. Calibrate the DPM using four calibration points-zero, LCL (lower control limit), UCL (upper control limit), and full scale. Refer to the Quick Start Guide, or the DPM manual shipped with each

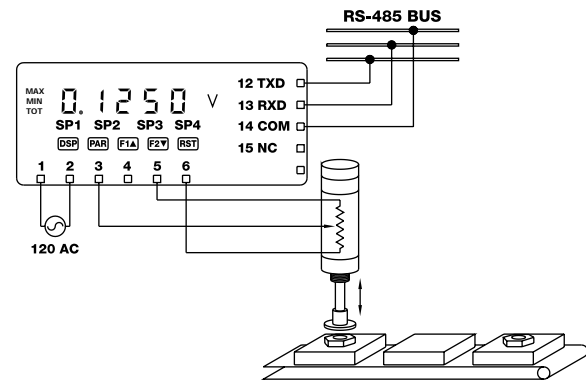

control unit for instructions. Configure the PLC with an RS-485 communication port. Program the PLC ladder logic according to your particular application. The ladder logic can be written to accommodate different sets of specifications for different product lines, making set up for the different products much easier and less time consuming.

Example Two

Read the programmable alarm outputs of the DPM from a PLC input card. The DPM outputs can be used to determine if a part measures to the proper tolerance or not. Alarm output one can be programmed to turn on at the upper control limit (UCL) of the part specification, and alarm output two can be programmed to turn on at the lower control limit (LCL) of the part specification. When the PFC is extended to measure the part, the PLC can read the DPM setpoint alarm outputs to

determine if the part conforms to the proper specifications. After the PFC is extended against the part, the PLC reads the DPM outputs. If no setpoint alarm turns on, this means that the PFC displacement is above the UCL, and the part is too big. If setpoint alarm one is on, this means that the part is in the good tolerance zone. If both setpoint alarms are on, this means that the part is either too small, or the part is not present.

Model DPM - 1 / 8 DIN Universal DC Input Panel Meter

Bimba Model DPM Digital Set Point Controller

The Bimba DPM may be used with the Position Feedback Cylinder. The controller provides a digital LED readout that may be calibrated to indicate the position of the cylinder in desired units. The PFC/DPM combination is ideal for measuring and gauging applications. The controller includes the following features:

- PFC Compatible Excitation and Input Impedance
- 120 VAC Input Voltage
- 16 Point Calibration Feature for Increased PFC Linearity
- Max and Min Reading Memory
- 5 Digit Display
- Programmable Function Keys
- Optional Serial Communication, Including RS-232, RS-485 and DeviceNet®
- Optional Analog Card with 16 bit Resolution
- NEMA 4X/IP65 Sealed Front Bezel
- CE Compliant
- Fast Input and Output Rates-Programmable

General Description

The DPM embodies many features and performance capabilities to suit a wide range of indication requirements. The meter employs advanced technology for stable, drift free readout, while incorporating features that provide flexibility now and in the future with Plug-in option cards. The option cards afford the opportunity to easily configure the meter for the needs of the present while providing an upward migration path as control and indication needs evolve.

The DPM provides a precision excitation compatible for Bimba's PFC. 16-point input scaling feature improves PFC linearity if necessary. The meter provides a Max and Min reading memory with programmable capture time. The capture time is used to prevent detection of false max and min readings which may occur during start-up or unusual process events.

The signal totalizer (integrator) can be used to compute a time-input product. This can be used to provide a readout of totalized flow, calculate service intervals of motors and pumps, etc. The totalizer can also accumulate batch weighing operations.

The DPM comes standard with four sourcing setpoint outputs. The setpoint alarms can be configured in modes to suit a variety of control and alarm requirements.

- High and low absolute, high and low deviation and band acting
- Balanced or unbalanced hysteresis
- On and off delay timers
- Auto reset or latching modes
- Reverse phase output and/or panel indicator
- Selection of alternate list of setpoint values

Optional accessory cards also facilitate bus communications. These include RS232, RS485 and DeviceNet. Readout values and setpoint alarm values can be controlled through the bus. Additionally, the meter has features that allow a remote computer to directly control the outputs of the meter. This is useful during commissioning phases and diagnostic use. With a communication card installed, set-up software allows configuration from a PC. The configuration data can be saved to a file for later recall. Contact Bimba for information if required.

Once the meter has been initially configured, the parameter list may be locked out from further modification in it's entirety or only the setpoint values can be made accessible.

The meter has been specifically designed for harsh industrial environments. With NEMA4 X/IP65 sealed bezel and extensive testing of noise effects to CE requirements, the meter provides a tough and reliable local readout.

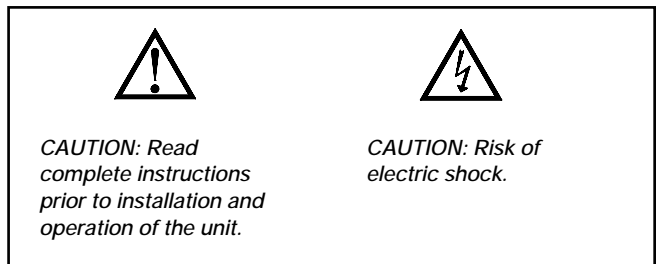

Dimensions "In Inches (mm)"

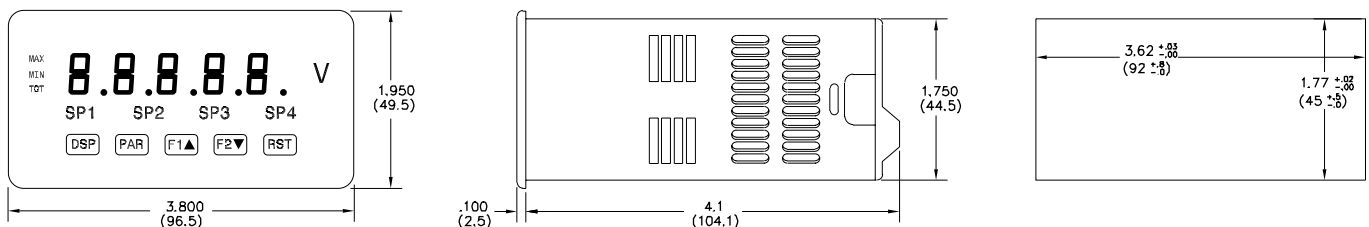

Note: Recommended minimum clearance (behind the panel) for mounting clip installation is 2.1" (53.4) H x 5.5" (140) W.

DPM Specifications

- DISPLAY:** 5 digit, 0.56" red LED, (-19999 to 99999)
- POWER:** 85 to 250 VAC, 50/60 Hz, 15 VA
Isolation: 2300 Vrms for 1 min. to all inputs and outputs.
- ANNUNCIATORS:**
MAX - max readout selected
MIN - min. readout selected
TOT - totalizer readout selected, flashes when total overflows
SP1 - setpoint alarm 1 is active
SP2 - setpoint alarm 2 is active
SP3 - setpoint alarm 3 is active
SP4 - setpoint alarm 4 is active
Units Label - software controlled units label backlight
- KEYPAD:** 3 programmable function keys, 5 keys total
- A/D CONVERTER:** 16 bit resolution
- UPDATE RATES:**
A/D conversion rate: 20/readings sec
Step response: 200 msec. max. to within 99% of final readout value (digital filter and internal zero correction disabled)
700 msec. max. (digital filter disabled, internal zero correction enabled).
The meter periodically (every 12 seconds) imposes a 500 msec delay to compensate for internal zero drift. If the delay affects applications where step response is critical, it can be defeated. Set the display update to 20/sec to disable. In this case, add a zero error of 0.1% FS over the 0 to 50°C range.
Display update rate: 1 to 20 updates/sec
Setpoint output on/off delay time: 0 to 3275 sec
Analog output update rate: 0 to 10 sec
Max./Min. capture delay time: 0 to 3275 sec
- RANGE OVERLOAD RESPONSE:**
Display flashes [LOLO] at approximately 105% above range
Display flashes [ULUL] at approximately -5% below range
- DPM PFC INPUT:**

Accuracy* (18 to 28C)	Accuracy* (0 to 50C)	Impedance/ Compliance	Max Continuous Overload	Resolution
0.03% of reading +3 mV	0.12% of reading + 4 mV	1.066 Mohm	300 V	1mV

* After 20 minute warm-up. Accuracy is specified in two ways: Accuracy over an 18 to 28°C and 10 to 75% RH environment; and accuracy over a 0 to 50°C and 0 to 85%RH (non-condensing environment). Accuracy over the 0 to 50°C range includes the temperature coefficient effect of the meter.

- EXCITATION POWER:**
9V \pm 4% initial value regulated, 130 mA max.
- LOW FREQUENCY NOISE REJECTION:**
Normal Mode: > 60 dB @ 50 or 60 Hz \pm 1%, digital filter off
Common Mode: >100 dB, DC to 120 Hz
- USER INPUTS (Logic Level):** Three software defined user inputs, jumper selectable for sink/source logic
Max. Continuous Input: 30 VDC

INPUT STATE	SINKING INPUTS (DEFAULT)	SOURCING INPUTS
	Active	22 K Ω pull-up to +5 V $V_{IN} < 0.7$ VDC
Inactive	$V_{IN} > 2.5$ VDC	$V_{IN} < 0.7$ VDC

Isolation To Sensor Input Common: Not isolated

- TOTALIZER:**
Time Base: second, minute, hour, or day
Time Accuracy: 0.01% typical
Decimal Point: 0 to 0.0000
Scale Factor: 0.001 to 65.000
Low Signal Cut-out: -19,999 to 99,999

Total: 9 digits, display alternates between high order and low order readouts

- CUSTOM LINEARIZATION:**
Data Point Pairs: Selectable from 2 to 16
Display Range: -19,999 to 99,999
Decimal Point: 0 to 0.0000
- SERIAL COMMUNICATIONS:** (RS232 or RS485)
Isolation To Sensor & User Input Commons:
500 Vrms for 1 min.
Working Voltage: 50 V
Not Isolated from all other commons.
Data: 7/8 bits
Baud: 300 to 19200
Parity: no, odd or even
Bus Address: selectable 0 to 99, Max. 32 meters per line (RS485)
Transmit Delay: Selectable for 2 to 50 msec or 50 to 100 msec (RS485)
- ANALOG OUTPUT :**
Types: 0 to 20 mA, 4 to 20 mA or 0 to 10 VDC
Isolation To Sensor & User Input Commons: 500 Vrms for 1 min.
Working Voltage: 50 V
Not Isolated from all other commons.
Accuracy: 0.17% of FS (18 to 28°C); 0.4% of FS (0 to 50°C)
Resolution: 1/3500
Compliance: 10 VDC: 10 K Ω load min.
20 mA: 500 W load max.
- Quad Sourcing Open Collector:**
(Standard with DPM):

QUAD SOURCING OUTPUT FIELD TERMINALS

- 20 - EXTERNAL SUPPLY
- 21 - 01 SRC.
- 22 - 02 SRC.
- 23 - 03 SRC.
- 24 - 04 SRC.
- 25 - COMMON

Type: Four isolated sourcing PNP transistors.
Isolation To Sensor & User Input Commons: 500 Vrms for 1 min.
Working Voltage: 50 V
Not Isolated from all other commons.
Rating: Internal supply: 24 VDC \pm 10%, 30 mA max. total all four outputs.
External supply: 30 VDC max., 100 mA max. each output.

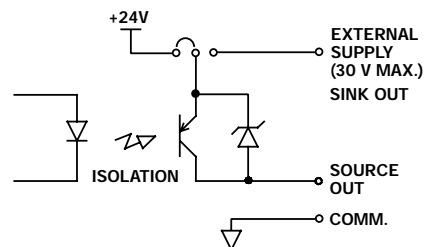
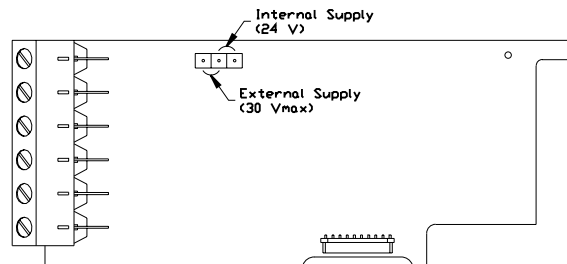

DPM Specifications Cont.

Optional Quad Relay Card:

(Optional Accessory Card DPM-R):

QUAD RELAY OUTPUT FIELD TERMINALS

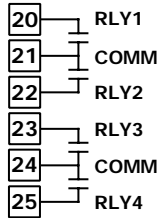

Type: Four FORM-A relays
Isolation To Sensor & User Input Commons: 2300 Vrms for 1 min.
Contact Rating: One Relay Energized: 3 amps @ 250 VAC or 30 VDC (resistive load), 1/10 HP @120 VAC, inductive load. Total current with all four relays energized not to exceed 4 amps
Life Expectancy: 100K cycles min. at full load rating. External RC snubber extends relay life for operation with inductive loads.

17. ENVIRONMENTAL CONDITIONS:

Operating Temperature Range: 0 to 50°C (0 to 45°C with all three plug-in cards installed)

Storage Temperature Range: -40 to 60°C

Operating and Storage Humidity: 0 to 85% max. non-condensing

Altitude: Up to 2000 meters

18. CERTIFICATIONS AND COMPLIANCES:

ELECTROMAGNETIC COMPATIBILITY

Notes:

1. Self-recoverable loss of performance during EMI disturbance at 10 V/m: Measurement error less than 2% of full scale.

For operation without loss of performance:

Mount unit in a metal enclosure (Buckeye SM7013-0 or equivalent)

Route power and I/O cables in metal conduit connected to earth ground.

Refer to the Application Guide for additional EMC information.

Immunity to EN 50082-2

electrostatic discharge	EN 61000-4-2	level 3; 8 Kv air
electromagnetic RF fields	EN 61000-4-3	level 3; 10 V/m 80 MHz - 1 GHz
fast transients (burst)	EN 61000-4-4	level 4; 2 Kv I/O level 3; 2 Kv power
RF conducted interference	EN 61000-4-6	level 3; 10 V/rms 150 KHz - 80 MHz
simulation of cordless telephones	ENV 50204	level 3; 10 V/m 900 MHz ±5 MHz 200 Hz, 50% duty cycle

Emissions to EN 50081-2

RF interference	EN 55011	enclosure class A power mains class A
-----------------	----------	--

19. **CONNECTIONS:** High compression cage-clamp terminal block
Wire Strip Length: 0.35" (9 mm)
Wire Gauge Capacity: One 14 AWG solid or Two 18 AWG

20. **CONSTRUCTION:** This unit is rated for NEMA 4X/IP65 indoor use. IP20 Touch safe. Installation Category II, Pollution Degree 2. One piece bezel/case. Flame resistant. Synthetic rubber keypad. Panel gasket and mounting clip included.

21. **WEIGHT:** 10.4 oz. (295 g)



Safety Summary

All safety related regulations, local codes and instructions that appear in the manual or on equipment must be observed to ensure personal safety and to prevent damage to either the instrument or equipment connected to it. If equipment is used in a manner not specified by the manufacturer, the protection provided by the equipment may be impaired. Do not use this unit to directly command motors, valves, or other actuators not equipped with safeguards. To do so can be potentially harmful to persons or equipment in the event of a fault to the unit.

Jumper Link Functions

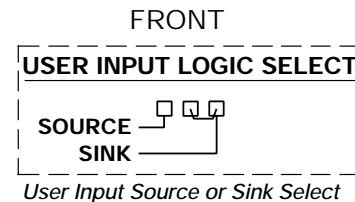

Front Panel

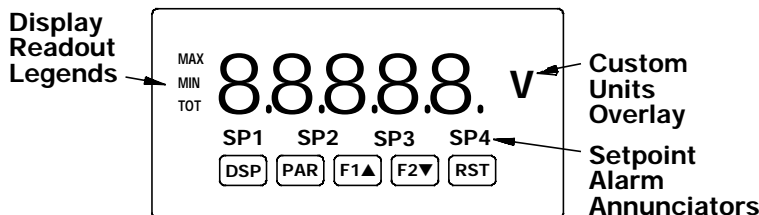

KEY DISPLAY MODE OPERATION

DSP	Index display through max/min/total/input readouts
PAR	Access parameter list
F1▲	Function key #1; hold for 3 seconds for Second Function #1
F2▼	Function key #2; hold for 3 seconds for Second Function #2
RST	Reset (function key)

PROGRAMMING MODE OPERATION

Quit programming and return to display mode
Store selected parameter and index to next parameter
Increment selected parameter value
Decrement selected parameter value
Hold with F1▲, F2▼ to scroll value by x1000

Basic Connections

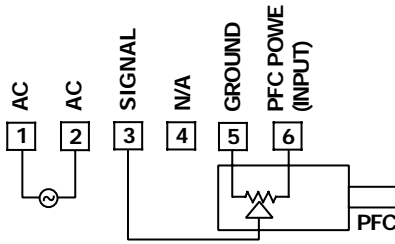

Note: Option card field connections are supplied with the card.

Wire Colors

Wires	6" Leads	Plug
Input	Red	Blue
Ground	Black	Black
Output	White	Brown

Custom Units Overlay

The meter has a backlighted units indicator that can be customized to the application. The backlight is turned on by programming the "b-LLt" parameter. Overlays are available in the Units Label Kit. To install an overlay, remove the unit from the case. Select the label and apply it to the label frame, noting that the label must be aligned accurately. Install the label frame to the display board in the alignment holes located on the right side of the display.

Plug-In Cards

The meter has three plug-in card slots. Each slot is dedicated to a specific function. These functions are:

- Setpoint Outputs
- Analog Outputs
- Communication Option

The plug-in cards can be used in any combination, however, it is only possible to use one type of card from each category. Cards can be installed initially, or at a later date as system needs arise.

Devicenet Plug-In Card

A DeviceNet communication port can be added to the meter. DeviceNet is a high level bus protocol based upon the CAN specification. The protocol allows the integration of devices of different types and manufacturers within a common communication framework.

Analog Output Plug-In Card

The analog output is available as a Plug-in card. Either the 20 mA or the 10 V output can be used. The output can be scaled independent of the input range. Reverse acting output is possible by reversing the scaling point positions. Other features are selectable update rate and output source selection.

RS485 Plug-In Card

An RS485 communication port can be added with a Plug-in card. RS485 offers multi-drop bus communications. All devices connect in parallel on a 485 bus. Only one device is permitted to transmit at any one time, while all other devices are in receive mode. The meter controls the bus when it transmits data, otherwise the meter is in the receive mode.

RS232 Plug-In Card

An RS232 communication port can be installed with a Plug-in card. RS232 is intended to allow only 2 devices to communicate to each other (i.e., printer or computer). For more information, See DPM Serial Application Guide.

Inputs

Voltage Inputs

The Bimba PFC uses the $\pm 20V$ range (default).

Scaling

The meter has been factory calibrated on all ranges as a basic multimeter (voltmeter/ammeter/ohmmeter). The basic meter readout can then be post scaled to read out in the process units (level, flow, temperature, etc.). The meter provides two ways in which to scale the display:

Key-in: Key in the input and display scaling points using known data.

Apply: Apply the actual input value and key in the corresponding display value. The meter records the input value applied.

For processes that require linearity compensation, up to 16 scaling points can be used for correction. The scaling range is extended up to five digits of resolution with selectable display rounding factors.

Input Features

A unique adaptive input filter is used. Whenever the difference between one reading and the next is less than the filter band value, the input is filtered. When the difference exceeds the filter band value, the input is not filtered. This avoids the usual compromise between using a relative high time constant for good noise rejection and using a low time constant filter for quick step response.

The readout can be corrected for process zero errors with an offset value. A tare function zeros the readout via a function operation.

Function Keys and User Inputs

The Function Keys and User inputs can be programmed to perform specific meter control operations. Function Keys #1 and #2 each have two types of functions, primary and secondary. The primary function is executed the instant the key is pressed. Holding the key for three seconds executes the second function. If the key is not held for 3 seconds, the second function is not executed. To implement a hidden key, program no function for the primary and program the desired function for the second.

The three user inputs can be selected for sinking or sourcing logic.

Max and Min Reading Detection

The meter records the maximum (max) and minimum (min) process inputs. Conditions such as valve activation, sudden change in material flow rate, etc., can result in false peaks which are not reflective of the true maximum and minimum of the process. In this case, Max and Min capture delay times can be used to prevent the detection of false maximums and minimums.

Basic Connections

Parameter Lock Mode

A user input can be used to lock the parameter list. When the user input is active, the meter is in the protected parameter mode, where it is only possible to access the setpoint values and the security code.

It is possible to lock the parameter list without using a user input as a program lock function. In this case, set the security code to a non-zero value. With a non-zero security value set, press the PAR Key to view the programmed setpoint values. The security code requires a “key” value to gain access to the full parameter list.

Installation

The DPM meets NEMA 4X/IP65 requirements for indoor use when properly installed. The unit is intended to be mounted into an enclosed panel. Prepare the panel cutout to the dimensions shown in the Dimensions drawing. Remove the panel latch and cardboard sleeve from the unit and discard the cardboard sleeve. Slide the panel gasket over the rear of the unit to the back of the bezel. The unit should be installed fully assembled. Insert the unit into the panel cutout. While holding the unit in place, push the panel latch over the rear of the unit so that the tabs of the panel latch engage in the slots on the case. The panel latch should be engaged in the farthest forward slot possible. To achieve a proper seal, tighten the latch screws evenly until the unit is snug in the panel (Torque to approximately 7 in-lbs [79N-cm]). Do not over-tighten the screws.

Ordering Information

Model Number	Description	List Prices
DPM	Base Unit - Includes Excitation, Quad Solid State Outputs	\$410.00
DPMA	Base Unit with Analog Card	495.00
DPMS	Base Unit with RS-485 Serial Output	480.00
DPM-485	RS-485 Plug-In Accessory Card	70.00
DPM-232	RS-232 Plug-In Accessory Card	70.00
DPM-DNET	DeviceNet Plug-In Accessory Card	170.00
DPM-A	Analog Plug-In Accessory Card	110.00
DPM-R	Quad Form A 120 VAC Relay Plug-In Accessory Card	70.00