

SERIES SM BASE SLIDES

Compact modular base slides provide smooth linear motion at twice the thrust of a single bore cylinder.

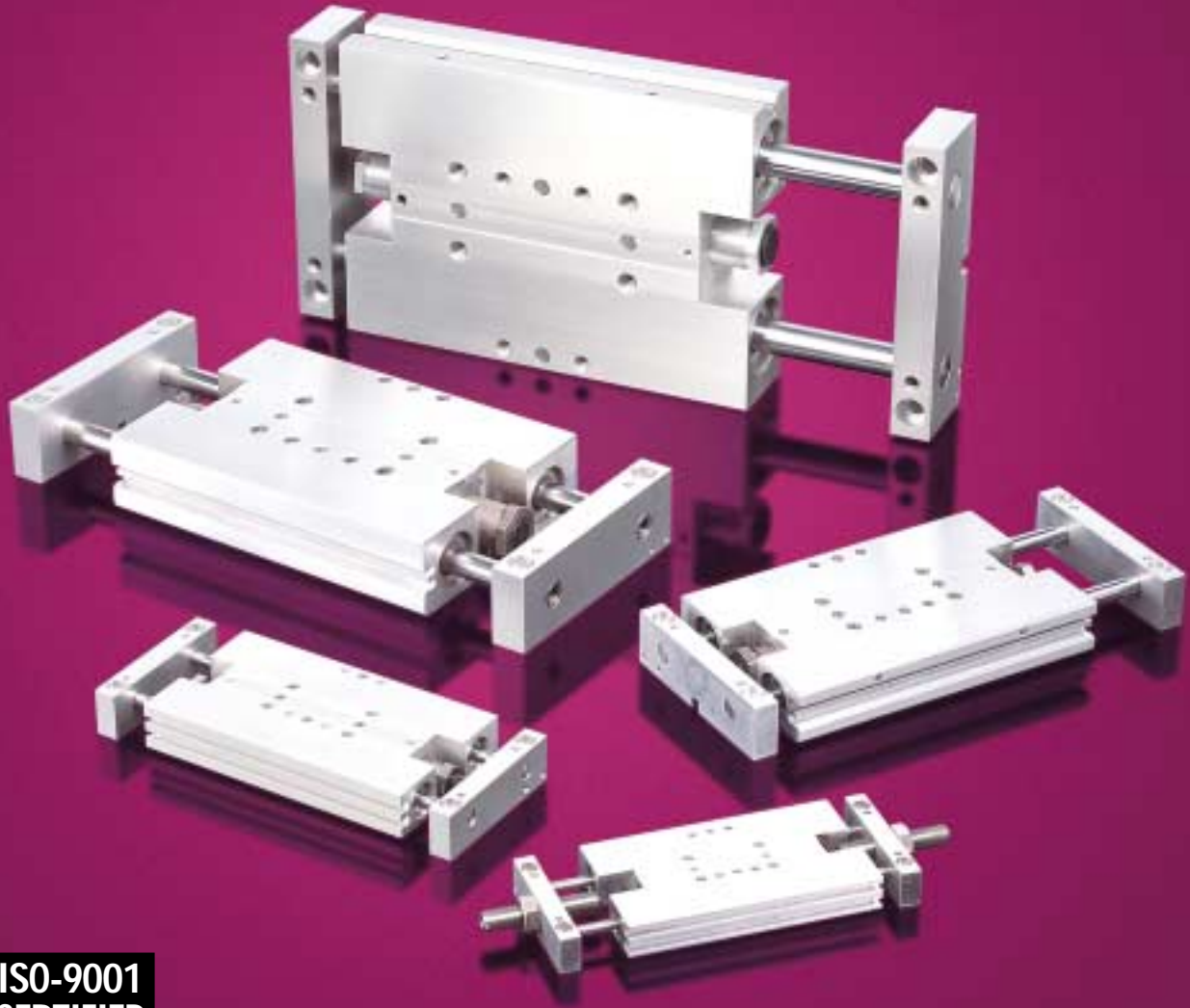

**ISO-9001
CERTIFIED**
Quality Management
System Certified

SM02



phd 
SOLUTIONS FOR INDUSTRIAL AUTOMATION

PHD, Inc. • P.O. Box 9070 • Fort Wayne, IN 46899 • (260) 747-6151 • FAX (260) 747-6754
www.phdinc.com • phdinfo@phdinc.com

ORDERING DATA: SERIES SM SLIDES

INDEX:

- Ordering Data Page 2
- Benefits Page 3
- Dimensions Page 4
- Engineering Data Pages 5 to 9
- Options Pages 10 to 14
- Accessories Page 15
- Stopping Capacity Page 16
- Shock Absorber Selection Guide Page 17
- Slide Sizing Example Page 18
- Exploded View Page 19
- Parts Lists & Kits Page 20

TO ORDER SPECIFY:

Product, Series, Type, Design No., Bore Size, Travel, Travel Adjustment, Shock Absorber Installed, and Miscellaneous Options.

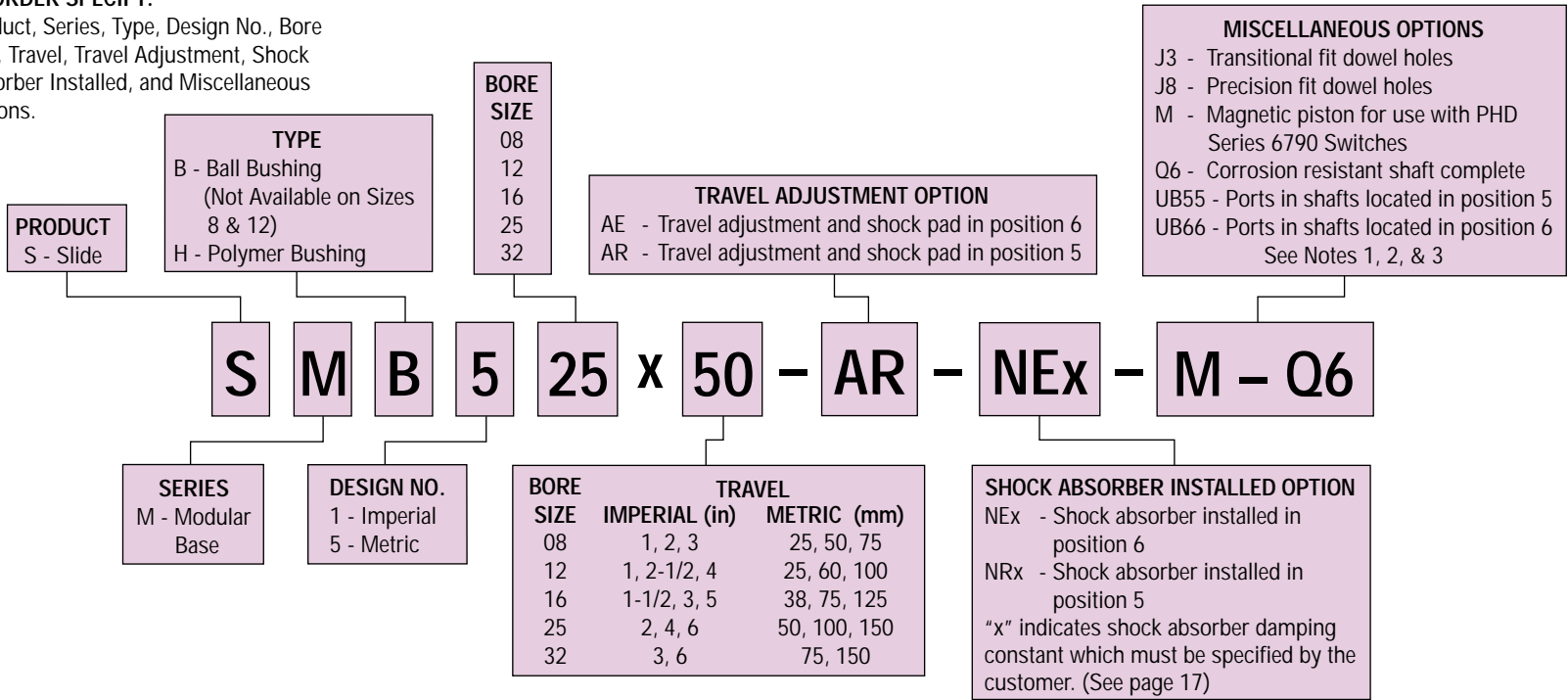

SHOCK ABSORBER REPLACEMENTS

BORE SIZE	PART NO.
08	68149-01-x
12	68149-02-x
16	68015-01-x
25	67127-01-x
32	71451-01-x

SERIES 6790 SWITCHES

PART NO.	DESCRIPTION
67902-1-02	NPN (Sink) or PNP (Source) DC Reed, 2 m cable
67902-1-05	NPN (Sink) or PNP (Source) DC Reed, 5 m cable
67903-1-02	NPN (Sink) DC Solid State, 2 m cable
67903-1-05	NPN (Sink) DC Solid State, 5 m cable
67904-1-02	PNP (Source) DC Solid State, 2 m cable
67904-1-05	PNP (Source) DC Solid State, 5 m cable
67922-1	NPN (Sink) or PNP (Source) DC Reed, Quick Connect
67923-1	NPN (Sink) DC Solid State, Quick Connect
67924-1	PNP (Source) DC Solid State, Quick Connect
63549-02	2 meter Cordset with Quick Connect
63549-05	5 meter Cordset with Quick Connect

NOTE:

- 1) UBxx options include NPT port adaptors for imperial units and BSPP port adaptors for metric units on SMxx25, SMxx32 units, and barb fittings on SMxx12 units.
- 2) -UB and -Q6 options not available on Series SMxx08 units.
- 3) -Q6 options not available on Series SMxx12 units. For ball bushings on Series SMxx12 units, consult your local PHD distributor.

BENEFITS: SERIES SM SLIDES

BENEFITS

- Series SM Slides provide smooth linear motion at twice the thrust of a single bore cylinder.
- Available in five bore sizes with a choice of travel lengths to fit a wide range of applications. Optional travel adjustments and shock absorbers can provide precise adjustment of travel.
- Units with precision ball bushings provide more rigidity and can also carry a heavier load at higher velocities.
- Units with polymer bushings cost less and provide quieter operation.
- Available in both imperial and metric versions for applications in worldwide markets.
- Fully integrated shock absorbers or travel adjustments with shock pads allow easy adjustment of travel without increasing overall package length. External shock absorbers and travel adjustments available on size 08.
- Slide body incorporates twin switch slots for flush installation of PHD's new Series 6790 Reed and Solid State Switches.
- All units are 8 mm proximity switch ready using external mounting kits. This prevents flexing of the electrical connectors of the switches. Refer to page 15 for proximity switch mounting kits.
- Modular mounting pattern on slide body allows quick connect with Series STP slides without the need for transition plates. Refer to page 15 for modular mounting details and kits.
- Standard stainless steel fasteners eliminate the need for costly corrosion resistant options. Combined with -06 shaft option provides a completely corrosion resistant unit.
- Optional porting through the guide shafts allows the slide body to move without flexing the incoming air lines. Not available on size 08.
- Wider shaft spacing increases stability and reduces the amount of deflection in roll moment applications.

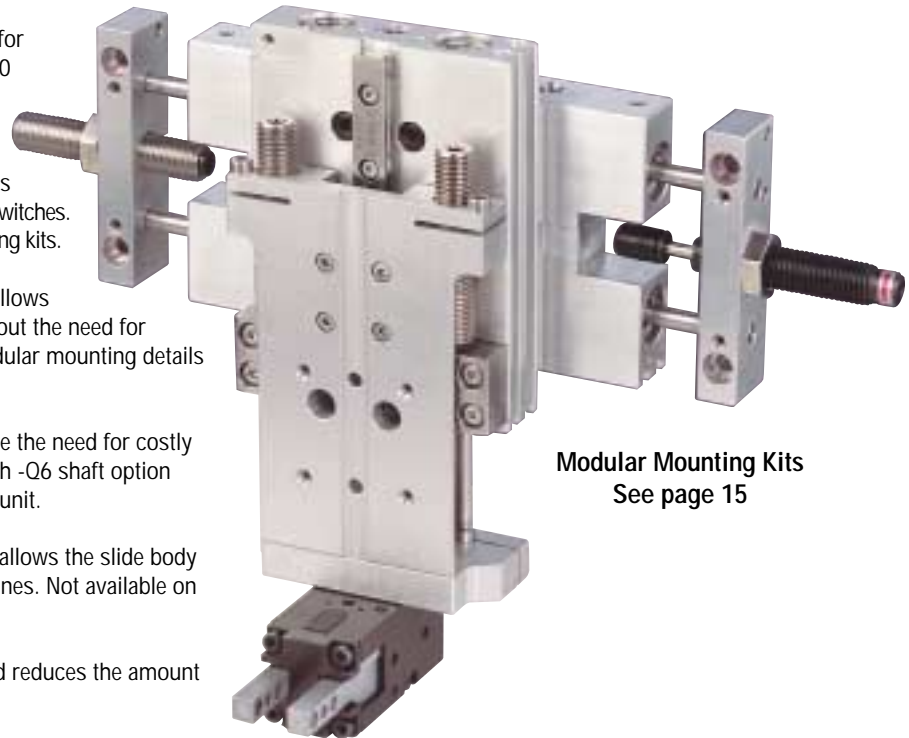

Modular Mounting Kits
See page 15

SPECIFICATIONS	SMHx08 AND SMHx12	SMxx16, SMxx25 AND SMxx32
POWER SOURCE	Two cylinders built into the slide body	
WORKING PRESSURE	20 psi min - 150 psi max at zero load [1.4 to 10 bar]	
TEMPERATURE RANGE	-20° to +180°F [-29° to 82°C]	
LUBRICATION	Permanent for Non-Lubricated or Lubricated Air	
GUIDE SHAFTS	Stainless Steel	Hard Chrome Plated Steel
BUSHINGS	Internally Lubricated Engineered Polymer or Recirculating Ball Bushings	
TOOL PLATE	Anodized Aluminum Alloy	
BODY	Anodized Aluminum Alloy	

DIMENSIONS: SERIES SM SLIDES

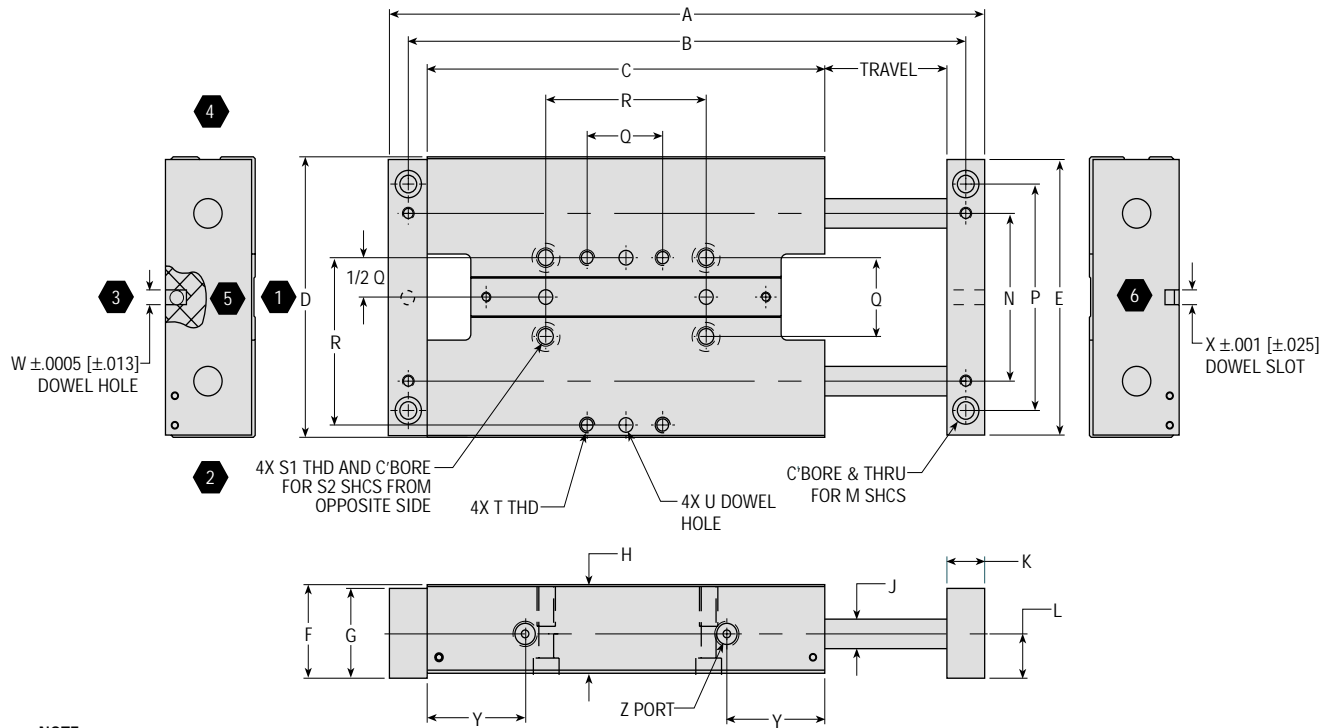

NOTE:
1) NUMBERS ENCLOSED BY A HEX INDICATE POSITION

LETTER DIM.	BORE SIZE																	
	08			12				16				25				32		
	in	mm	in	mm	in	mm	in	mm	in	mm	in	mm	in	mm	in	mm		
TRAVEL	1 25	2 50	3 75	1 25	2-1/2 60	4 100	1-1/2 38	3 75	5 125	2 50	4 100	6 150	3 75	6 150	3 75	6 150		
A	5.551 141.0	7.559 192.0	9.527 242.0	6.614 168.0	9.606 244.0	12.64 321.0	8.032 204.0	11.024 280.0	15.040 382.0	9.922 252.0	13.938 354.0	17.914 455.0	12.638 321.0	18.622 473.0	12.638 321.0	18.622 473.0		
B	5.236 133.0	7.244 184.0	9.212 234.0	6.220 158.0	9.212 234.0	12.24 311.0	7.599 193.0	10.591 269.0	14.607 371.0	9.292 236.0	13.308 338.0	17.284 439.0	11.890 302.0	17.874 454.0	11.890 302.0	17.874 454.0		
C	3.878 98.5	4.882 124.0	5.866 149.0	4.803 122.0	6.299 160.0	7.815 198.5	5.630 143.0	7.126 181.0	9.134 232.0	6.634 168.5	8.642 219.5	10.630 270.0	8.110 206.0	11.102 282.0	8.110 206.0	11.102 282.0		
D		2.165 55.0			2.638 67.0			3.504 89.0			4.488 114.0			5.788 147.0				
E		2.126 54.0			2.638 67.0			3.425 87.0			4.409 112.0			5.630 143.0				
F		0.610 15.5			0.874 22.2			0.984 25.0			1.497 38.0			1.790 45.5				
G		0.590 15.0			0.807 20.5			0.945 24.0			1.437 36.5			1.673 42.5				
H		0.551 14.0			0.795 20.2			0.906 23.0			1.418 36.0			1.673 42.5				
J		0.157 4.0			0.236 6.0			0.315 8.0			0.472 12.0			0.630 16.0				
K		0.315 8.0			0.394 10.0			0.433 11.0			0.630 16.0			0.748 19.0				
L		0.315 8.0			0.457 11.6			0.531 13.5			0.709 18.0			0.954 24.2				
M		#5 M3			#8 M4			#10 M5			1/4 M6			5/16 M8				
N		1.142 29.0			1.496 38.0			1.969 50.0			2.684 68.2			3.486 88.5				
P		1.575 40.0			2.048 52.0			2.638 67.0			3.623 92.0			4.646 118.0				
Q		0.551 14.0			0.670 17.0			0.905 23.0			1.260 32.0			1.575 40.0				
R		1.102 28.0			1.496 38.0			1.929 49.0			2.677 68.0			3.386 86.0				
S1	8-32 x .315 DP [M4 x 0.7 x 8 DP]			10-24 x .375 [M5 x 0.8 x 9.5 DP]				1/4-20 x .500 DP [M6 x 1.0 x 12 DP]				5/16-18 x .625 DP [M8 x 1.25 x 16 DP]				3/8-16 x .750 DP [M10 x 1.5 x 20 DP]		
S2	#5 [M3]			#8 [M4]				#10 [M5]				1/4 [M6]				5/16 [M8]		
T	5-40 x .236 DP [M3 x 0.5 x 6 DP]			6-32 x .400 DP [M4 x 0.7 x 10 DP]				10-24 x .375 DP [M5 x 0.8 x 10 DP]				1/4-20 x .500 DP [M6 x 1.0 x 12 DP]				5/16-18 x .750 DP [M8 x 1.25 x 20 DP]		
U*	3 mm x 3 mm DP			4 mm x 4 mm DP				5 mm x 5 mm DP				6 mm x 6 mm DP				8 mm x 8 mm DP		
W	.1182 x .118 DP [3.002 x 3 DP]			.1576 x .157 DP [4.003 x 4 DP]				.1969 x .197 DP [5.001 x 5 DP]				.2363 x .236 DP [6.002 x 6 DP]				.3152 x .315 DP [8.006 x 8 DP]		
X	.1191 x .118 DP [3.025 x 3 DP]			.1586 x .157 DP [4.028 x 4 DP]				.1979 x .197 DP [5.027 x 5 DP]				.2372 x .236 DP [6.025 x 6 DP]				.3162 x .315 DP [8.031 x 8 DP]		
Y	0.925 23.5			1.416 36.0				1.437 36.5				1.634 41.5				2.008 51.0		
Z	10-32 PORT [M5 x 0.8 PORT]			10-32 PORT [M5 x 0.8 PORT]				10-32 PORT [M5 x 0.8 PORT]				1/8 NPT PORT [1/8 BSPP PORT]				1/8 NPT PORT [1/8 BSPP PORT]		

METRIC INFORMATION SHOWN IN []

* SEE OPTIONS PAGE 11 FOR J3 AND J8 OPTIONS FOR AVAILABLE TOLERANCE RANGES.

ENGINEERING DATA: SERIES SM SLIDES

PRESSURE RATINGS

All Series SM Slides have an operating pressure range of 20 psi minimum to 150 psi maximum [1.4 to 10 bar].

BREAKAWAY

Units have less than 20 psi [1.4 bar] breakaway with zero load. Typical breakaway pressures at zero load are as follows:
 Size 08 = 20 psi [1.4 bar]
 Size 12 = 15 psi [1 bar]
 Size 16, 25 and 32 = 7 psi [.5 bar]

OPERATING TEMPERATURE

Series SM Slides are designed for use in temperatures between 20° to 180° F [-29° to 82° C]. For temperatures outside this range, consult PHD or your local distributor.

SEALS

Series SM Slides utilize urethane and Nitrile seals which are compatible with standard paraffin-based lubrication oils used for pneumatic cylinders. For compatibility with other fluids, consult PHD or your local distributor.

LUBRICATION

All units are pre-lubricated at the factory for service under normal operating conditions. Slides are designed and tested with non-lubricated air. However, the use of lubricated air will extend life.

MAXIMUM SLIDE VELOCITY

Maximum slide velocity is 60 in/sec [1.5 m/sec]. This value is based on an unloaded slide at 87 psi [6 bar] operating pressure. All units are capable of higher velocities. However, PHD recommends using external flow controls to limit the velocity.

MAINTENANCE

In common with most PHD products, these slides are fully field repairable. Repair kits and main structural components are available as needed for extended service life.

TOTAL TRAVEL LENGTH

Tolerance on specified minimum travel length is +.098/-.000 [+2.5 mm/-0 mm].

UNIT WEIGHT

SIZE	TRAVEL		BASE WEIGHT		OPTION ADDERS			
	in	mm	lb	kg	-AR OR -AE lb	kg	-NEx OR -NRx lb	kg
08	1	25	0.55	0.25	0.06	0.03	0.06	0.03
	2	50	0.65	0.30				
	3	75	0.75	0.34				
12	1	25	2.0	0.91	0.03	0.01	0.05	0.02
	2-1/2	60	2.5	1.14				
	4	100	3.0	1.36				
16	1-1/2	38	2.0	0.91	0.12	0.05	0.14	0.06
	3	75	2.5	1.14				
	5	125	3.0	1.36				
25	2	50	4.6	2.09	0.29	0.13	0.34	0.15
	4	100	5.9	2.68				
	6	150	7.0	3.18				
32	3	75	8.8	3.97	0.2	0.09	0.35	0.16
	6	150	11.7	5.31				

SIZE	MINIMUM TRAVEL	
	in	mm
08	1	25
	2	51
	3	76
12	1	25
	2-1/2	63.5
	4	102
16	1-1/2	38
	3	76
	5	127
25	2	51
	4	102
	6	152
32	3	76
	6	152

MOUNTING THE UNIT

IMPORTANT! Units must be mounted and used as a gantry/ base slide. Units cannot be mounted and used as a cantilever slide. Consult PHD or your local distributor for a cantilever unit.

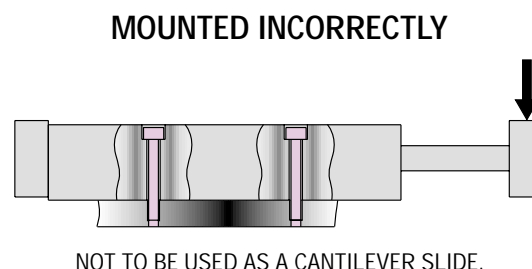
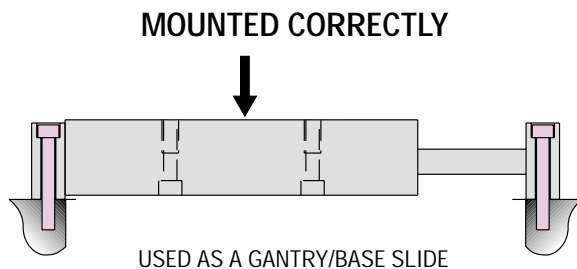

ENGINEERING DATA: SERIES SM SLIDES

SLIDE SELECTION

There are three major factors to consider when selecting a slide: thrust capacity, allowable static and dynamic moment capacity, and table deflection (as either pitch, yaw, or roll).

1 THRUST CAPACITY

Use the effective piston area (see thrust specifications) of the slide to determine if thrust is sufficient for the applied load. In horizontal applications, a slide with polymer bushings requires a higher breakaway pressure than a slide with linear ball bushings.

Approximate breakaway pressure for polymer bushings due to additional load is calculated as follows:

$$\text{psi or bar} = L \times .15 / A, \text{ where}$$

$$L = \text{Load on saddle lb [N]}$$

$$A = (\text{SMHx08}) = .15 [9.7]$$

$$A = (\text{SMHx12}) = .37 [24]$$

$$A = (\text{SMHx16}) = .59 [38]$$

$$A = (\text{SMHx25}) = 1.04 [67]$$

$$A = (\text{SMHx32}) = 2.5 [161]$$

Approximate breakaway pressure under load:
 $(L \times .15 / A) + \text{Zero Load Breakaway measured in psi or bar.}$

The above equations apply for direct loading only and are to be used as guidelines only.

THRUST SPECIFICATIONS

SIZE	SHAFT DIAMETER		BORE DIAMETER		TOTAL EFFECTIVE PISTON AREA	
	in	mm	in	mm	in ²	mm ²
08	0.157	4	0.315	8	0.12	75
12	0.236	6	0.472	12	0.27	172
16	0.315	8	0.630	16	0.47	302
25	0.472	12	0.984	25	1.17	756
32	0.630	16	1.260	32	1.87	1206

CYLINDER THRUST CALCULATION

	IMPERIAL	METRIC
F = Cylinder Force	$F = P \times A$	$F = 0.1 \times P \times A$
P = Operating Pressure	lb	N
A = Effective Area	psi	bar
	in ²	mm ²

2 STATIC AND DYNAMIC MOMENT CAPACITY

Use the following graphs and equations to determine the static and dynamic load capacities of the units.

(Continued on pages 7, 8, and 9)

MOMENT ORIENTATIONS

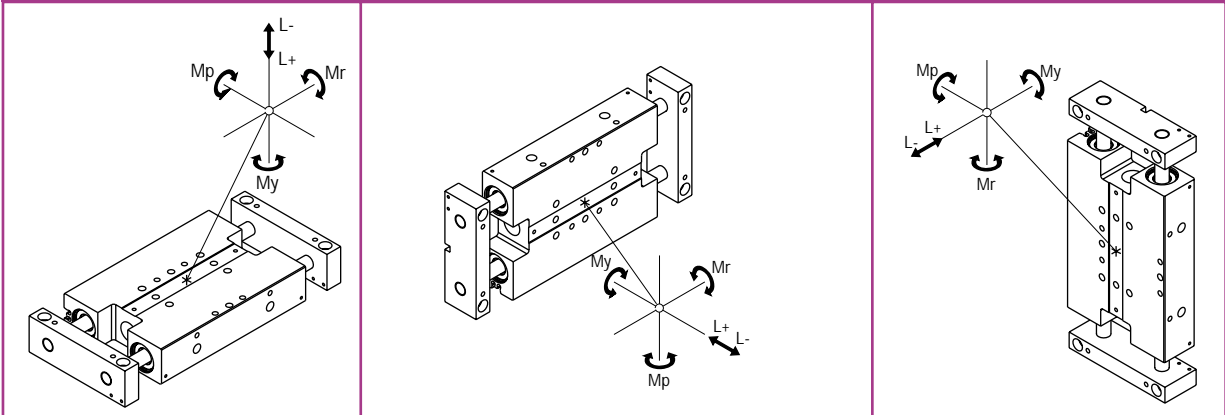

LOADING DIAGRAMS

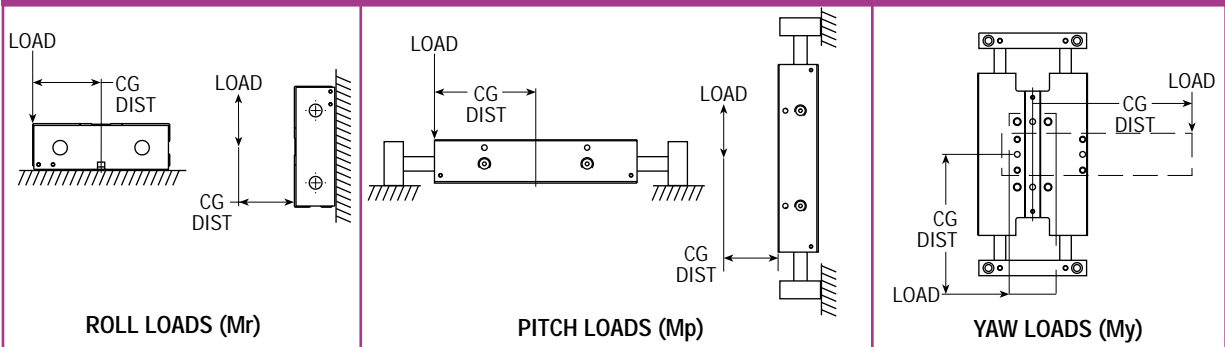

ENGINEERING DATA: SERIES SM SLIDES

MOMENT CAPACITY

Use the following equations to determine the load capacity for moment orientations. The load placed on the unit must be ≤ the value calculated. If load is ≥ L, review the next larger size of actuator.

B and C = Constants

CG = Distance to Load in [mm]

L = Max Load at CG Distance lb [N]

$L = C / (CG + B)$

POLYMER BUSHING MAX DYNAMIC PITCH AND YAW LOADS (Mp) (My)

SIZE	TRAVEL		B		C in-lb [Nmm]							
	in	mm	in	mm	10 in/sec [.25 m/sec]		20 in/sec [.51 m/sec]		30 in/sec [.76 m/sec]		60 in/sec [1.5 m/sec]	
SMHx08	1	25	1.60	40.6	8	904	4	438	2	280	1	140
	2	50	2.10	53.3	10	1130	5	579	3	370	2	185
	3	75	2.50	63.5	13	1468	6	706	4	452	2	226
SMHx12	1	25	2.04	51.8	33	3688	16	1844	10	1152	6	691
	2-1/2	60	2.54	64.5	41	4592	20	2296	13	1435	8	861
	4	100	3.55	90.2	57	6418	28	3209	18	2005	11	1203
SMHx16	1-1/2	38	2.53	64.3	86	9714	43	4861	29	3326	14	1535
	3	75	3.03	76.9	115	12989	57	6466	39	4424	18	2042
	5	125	4.03	102.5	153	17281	76	8618	52	5897	24	2722
SMHx25	2	50	2.45	62.2	178	20105	89	10064	59	6709	30	3355
	4	100	3.46	87.8	251	28350	125	14146	84	9431	42	4716
	6	150	4.45	112.9	322	36370	161	18188	107	12125	54	6062
SMHx32	3	75	3.32	84.3	411	46429	205	23214	139	15714	63	7143
	6	150	4.81	122.2	605	68402	303	34201	205	23151	93	10523

BALL BUSHING MAX DYNAMIC PITCH AND YAW LOADS (Mp) (My)

SIZE	TRAVEL		B		C	
	in	mm	in	mm	in-lb	Nmm
SMBx16	1-1/2	38	2.53	64.3	77	8697
	3	75	3.03	76.9	109	12255
	5	125	4.03	102.5	145	16333
SMBx25	2	50	2.45	62.2	149	16773
	4	100	3.46	87.8	209	23573
	6	150	4.45	112.9	268	30316
SMBx32	3	75	3.32	84.3	253	28585
	6	150	4.81	122.2	373	42143

Reduce loads by 30% for SMB units with -Q6 option.

MAX STATIC PITCH AND YAW LOAD CALCULATIONS (Mp) (My)

SIZE	TRAVEL		B		C	
	in	mm	in	mm	in-lb	Nmm
SMxx08	1	25	1.60	41	40	4519
	2	50	2.10	53	36	4067
	3	75	2.50	64	33	3728
SMxx12	1	25	2.04	51.8	126	14290
	2-1/2	60	2.54	64.5	109	12340
	4	100	3.55	90.2	117	13236
SMxx16	1-1/2	38	2.53	64	364	41126
	3	75	3.03	77	303	34234
	5	125	4.03	102	286	32314
SMxx25	2	50	2.45	62	931	105189
	4	100	3.46	88	900	101686
	6	150	4.45	113	881	99540
SMxx32	3	75	3.32	84.3	2058	232568
	6	150	4.81	122.2	2020	228252

POLYMER BUSHING MAX DYNAMIC ROLL LOADS (Mr)

SIZE	B		C in-lb [Nmm]							
	in	mm	10 in/sec [.25 m/sec]		20 in/sec [.51 m/sec]		30 in/sec [.76 m/sec]		60 in/sec [1.5 m/sec]	
SMHx08	0.642	16.3	2.9	328	1.4	158	0.9	102	0.5	56
SMHx12	0.746	18.9	12	1356	6	678	4	452	2	226
SMHx16	0.969	24.6	37	4179	19	2146	13	1468	6	678
SMHx25	1.184	30.1	97	10956	48	5422	32	3614	16	1807
SMHx32	1.716	43.6	225	25422	113	12767	76	8587	38	4293

BALL BUSHING MAX DYNAMIC ROLL LOADS (Mr)

SIZE	B		C	
	in	mm	in-lb	Nmm
SMBx16	0.969	24.6	35	3954
SMBx25	1.184	30.1	71	8022
SMBx32	1.716	43.6	137	15479

Reduce loads by 30% for SMB units with -Q6 option.

MAX STATIC ROLL LOADS (Mr)

SIZE	TRAVEL		B		C	
	in	mm	in	mm	in-lb	Nmm
SMxx08	1	25	0.642	16.3	16	1808
	2	50	0.642	16.3	11	1243
	3	75	0.642	16.3	8	904
SMxx12	1	25	0.746	18.9	46	5226
	2-1/2	60	0.746	18.9	32	3624
	4	100	0.746	18.9	25	2781
SMxx16	1-1/2	38	0.969	24.6	140	15813
	3	75	0.969	24.6	97	10956
	5	125	0.969	24.6	69	7794
SMxx25	2	50	1.184	30.1	455	51392
	4	100	1.184	30.1	308	34789
	6	150	1.184	30.1	234	26430
SMxx32	3	75	1.716	43.6	1064	120207
	6	150	1.716	43.6	721	81430

ENGINEERING DATA: SERIES SM SLIDES

Maximum static loads for all units are shown in the table at right. Maximum dynamic load for SMBxxx (ball bushings) are also provided in the table. Refer to graphs for maximum dynamic loads for polymer bushings.

CENTERED LOADS (L-) (L+)

SIZE	TRAVEL		MAX STATIC LOAD		MAX DYNAMIC LOAD (SMBxxx)	
	in	mm	lb	N	lb	N
08	1	25	25	111	4.5	20
	2	50	17	76		
	3	75	13	58		
12	1	25	62	276	16	71
	2-1/2	60	43	191		
	4	100	33	147		
16	1-1/2	38	144	641	36	160
	3	75	100	445		
	5	125	71	316		
25	2	50	380	1690	60	267
	4	100	260	1156		
	6	150	198	881		
32	3	75	620	2758	80	356
	6	150	420	1868		

DYNAMIC CENTERED LOAD GRAPHS FOR POLYMER BUSHING

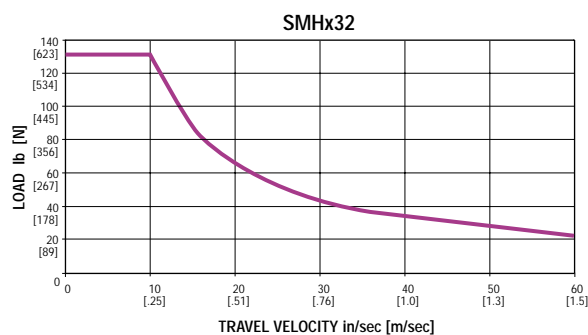
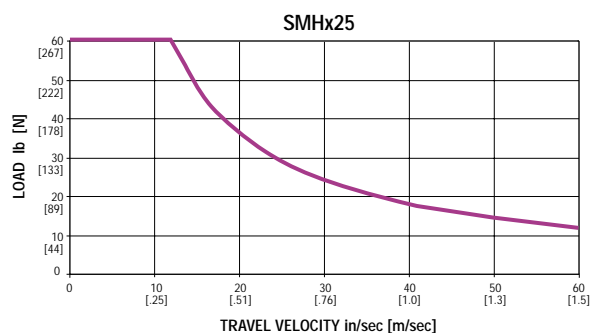
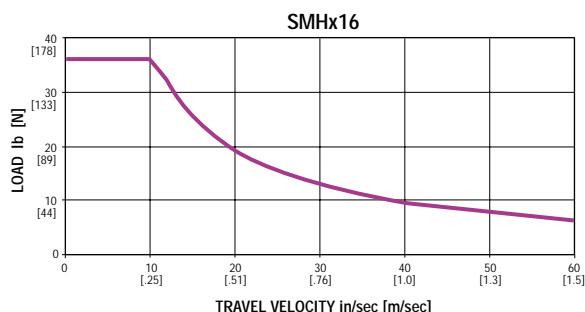
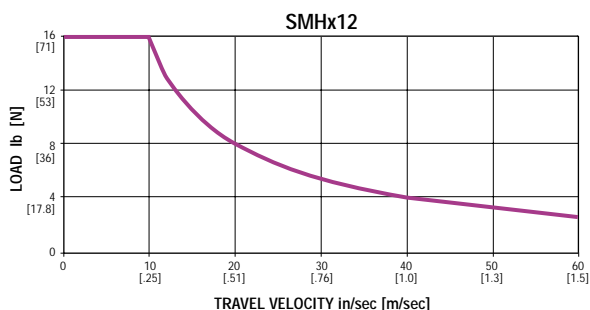
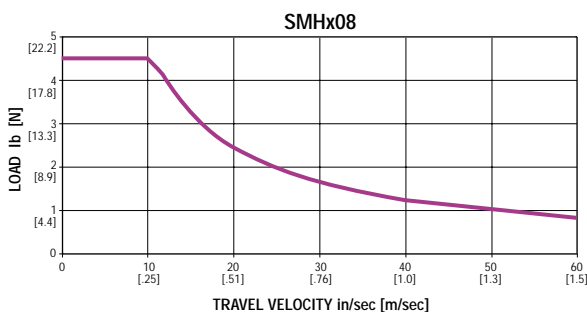

ENGINEERING DATA: SERIES SM SLIDES

3 DEFLECTION

Use the following graphs and equations to determine the static and dynamic deflection for a centered load with the saddle located at mid-travel. Deflections occurring at end-of-travel will be less than those indicated. Refer to PHD's Selection Software for deflections with pitch, yaw and roll moment loads.

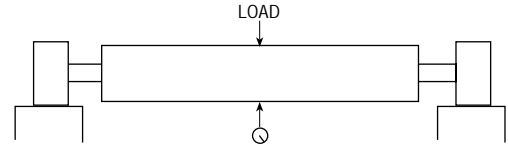

CENTERED LOAD DEFLECTION

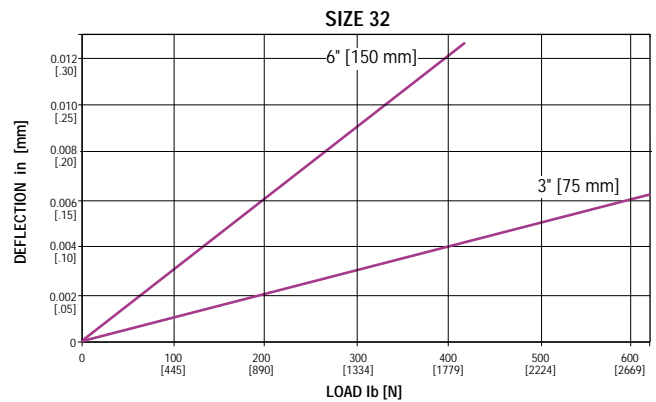
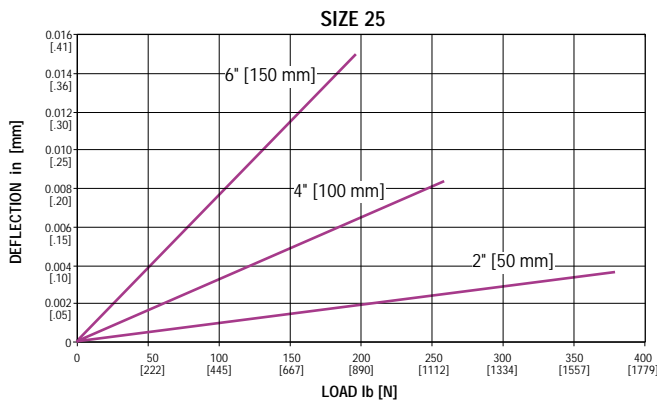
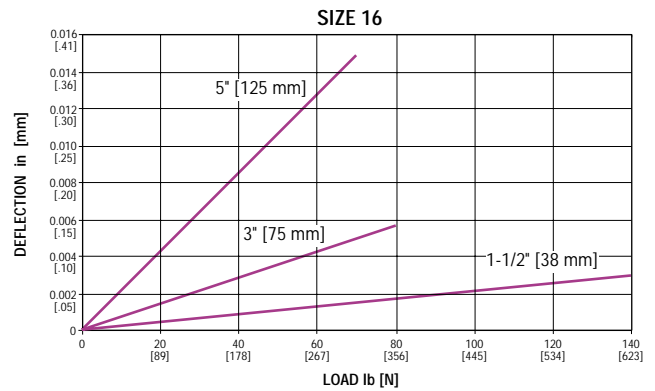
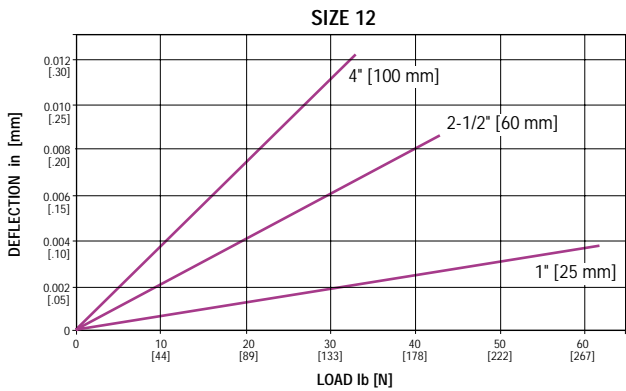
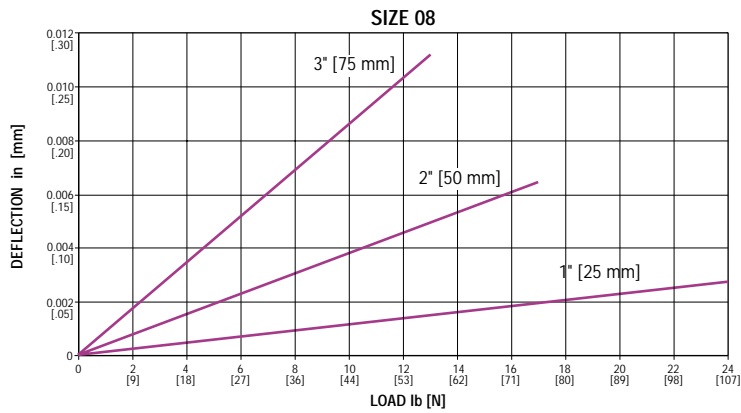

OPTIONS: SERIES SM SLIDES

AE AR TRAVEL ADJUSTMENT AND SHOCK PAD IN POSITION 5 (RETRACT) OR POSITION 6 (EXTEND)

SMxx12- SMxx32

These options provide internal travel adjustment with a shock pad in position 5 (retract) or position 6 (extend). Shock pads provide excellent noise reduction and energy absorption capability. Travel can be reduced by a maximum of 'A' per end shown in the table. Adjust travel adjustment screw with 'B' hex wrench and lock into place using 'C' hex wrench. A urethane material is provided under the locking set screw to prevent damage to the travel adjustment screw.

UNIT SIZE	A		B HEX		C HEX	
	in	mm	in	mm	in	mm
08	.5	13	.118	3	.438	11
12	.75	19	.500	13	.079	2
16	.75	19	.625	16	.079	2
25	1.0	25	.875	23	.079	2
32	1.5	38	1.0	26	.118	3

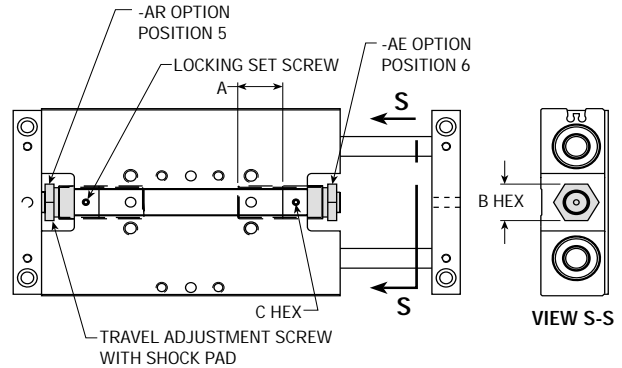

SMxx08 ONLY

These options provide external travel adjustment with a shock pad in position 5 (retract) or position 6 (extend). Shock pads provide excellent noise reduction and energy absorption capability. Travel can be reduced by a maximum of 'A' shown in the table. Adjust travel adjustment screw with 3 mm hex wrench and lock into place using 7/16" [11 mm] hex wrench.

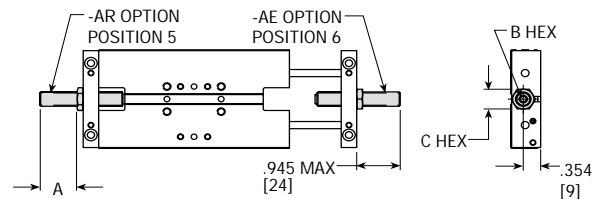

NEx NRx SHOCK ABSORBER INSTALLED IN POSITION 5 (RETRACT) OR POSITION 6 (EXTEND)

SMxx12- SMxx32

These options provide internal shock absorbers and travel adjustment in position 5 (retract) or position 6 (extend). Travel can be reduced by a maximum of 'A' shown in the table. Adjust travel with 'B' hex wrench and lock into place using 'C' hex wrench. A urethane material is provided under the locking set screw to prevent damage to the travel adjustment screw.

UNIT SIZE	A		B HEX		C HEX	
	in	mm	in	mm	in	mm
08	.5	13	.118	3	.438	11
12	.75	19	.500	13	.079	2
16	.75	19	.625	16	.079	2
25	1.0	25	.875	23	.079	2
32	1.5	38	1.0	26	.118	3

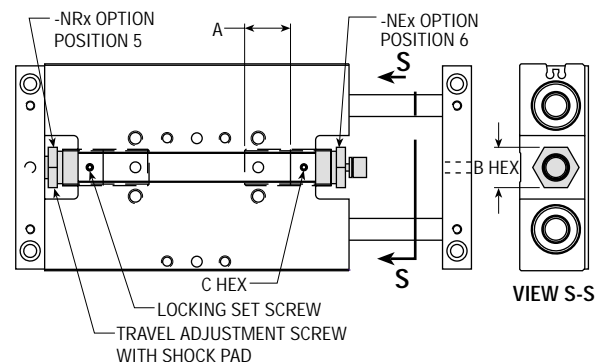

SMxx08 ONLY

These options provide shock absorbers and travel adjustment in position 5 (retract) or position 6 (extend). Travel can be reduced by a maximum of 'A' shown in the table. Adjust travel to the required position using a large screwdriver and lock into place using 7/16" [11 mm] hex wrench.

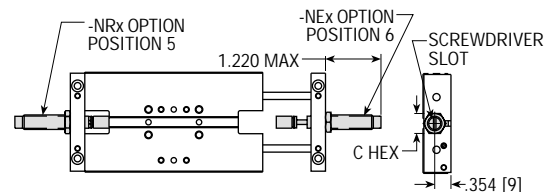

OPTIONS: SERIES SM SLIDES

J3 TRANSITIONAL FIT DOWEL PIN HOLES

This option provides a compromise fit between clearance and interference. Transitional fits are used where accuracy of location is important, but a small amount of clearance is permissible.

J8 PRECISION FIT DOWEL PIN HOLES

This option provides a H7 tolerance precision fit with dowel pins. Precision fits are used where accuracy of location is of prime importance and for parts requiring rigidity and alignment.

LETTER DIM	SIZE 08						SIZE 12						SIZE 16						SIZE 25						SIZE 32					
	in		mm		in		mm		in		mm		in		mm		in		mm		in		mm		in		mm			
TRAVEL	1	25	2	50	3	75	1	25	2-1/2	60	4	100	1-1/2	38	3	75	5	125	2	50	4	100	6	150	3	100	6	150		
C	3.878	98.5	4.882	124.0	5.866	149.0	4.803	122.0	6.299	160.0	7.815	198.5	5.630	143.0	7.126	181.0	9.134	232.0	6.634	168.5	8.642	219.5	10.630	270.0	8.110	206.0	11.102	282.0		
N	1.142 29.0						1.496 38.0						1.969 50.0						2.684 68.2						3.466 88.0					
Q	0.551 14.0						0.670 17.0						0.905 23.0						1.260 32.0						1.575 40.0					
R	1.102 28.0						1.496 38.0						1.929 49.0						2.677 68.0						3.386 86.0					
U	3 mm x 3 mm DP						4 mm x 4 mm DP						5 mm x 5 mm DP						6 mm x 6 mm DP						8 mm x 8 mm DP					

* SEE CATALOG DIMENSIONS FOR J3 AND J8 OPTIONS FOR AVAILABLE TOLERANCE RANGES.

Ø U DOWEL HOLE	TOLERANCE		
	STANDARD	J3 OPTION	J8 OPTION
3 mm	+0.004/-0.009 [+.010/-.024]	+0.013/+0.003 [+.033/+.008]	+0.004/-0.000 [+.010/-.000]
4 mm	+0.004/-0.009 [+.010/-.024]	+0.015/+0.005 [+.038/+.013]	+0.005/-0.000 [+.012/-.000]
5 mm	+0.004/-0.009 [+.010/-.024]	+0.015/+0.004 [+.038/+.010]	+0.005/-0.000 [+.012/-.000]
6 mm	+0.004/-0.009 [+.010/-.024]	+0.015/+0.005 [+.038/+.013]	+0.005/-0.000 [+.012/-.000]
8 mm	+0.004/-0.009 [+.010/-.024]	+0.016/+0.006 [+.041/+.015]	+0.006/-0.000 [+.015/-.000]

METRIC INFORMATION SHOWN IN [].

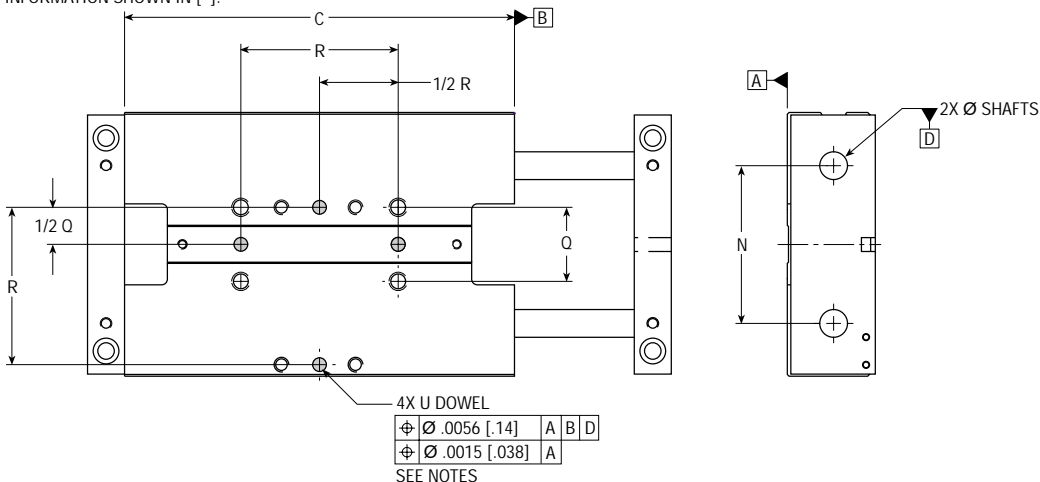

NOTES:

⊕ = POSITION TOLERANCE, THIS TOLERANCE DETERMINES THE LOCATION OF THE HOLES AND THE PERPENDICULARITY TO THE INDICATED DATUM FEATURES.

- 1) DATUM A REFERS TO THE MOUNTING SURFACE OF THE SLIDE BODY.
- 2) DATUM B REFERS TO THE THEORETICAL CENTERLINE OF THE LENGTH OF DIMENSION C.
- 3) DATUM D REFERS TO THE THEORETICAL CENTERLINE BETWEEN THE SHAFTS.
- 4) THE AXIS OF THESE DOWEL HOLES ARE LOCATED TO DATUM A, DATUM B, AND DATUM D WITHIN A .0056 [.14] DIAMETRICAL TOLERANCE ZONE. (SEE FIGURE)
- 5) THE AXIS OF THESE DOWEL HOLES ARE FURTHER CONTROLLED TO EACH OTHER AND PERPENDICULAR TO DATUM A WITHIN A .0015 [.038] DIAMETRICAL TOLERANCE ZONE.

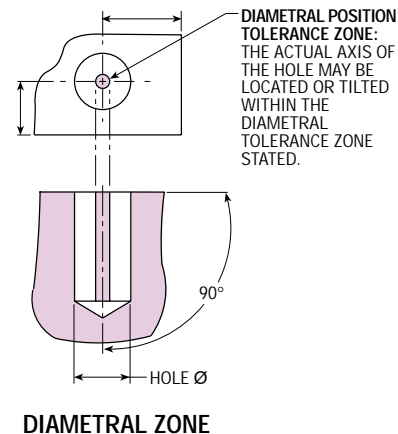

OPTIONS: SERIES SM SLIDES

M MAGNET FOR PHD SERIES 6790 MINIATURE REED AND SOLID STATE SWITCHES

This option equips the unit with a magnetic piston for use with PHD's Series 6790 Switch. The switch housing is completely contained by the slide body and provides a very compact switch design. The switches mount easily into two small grooves located on the side of the slide body and are locked into place with a set screw.

PART NO.	DESCRIPTION
67902-1-02	NPN (Sink) or PNP (Source) DC Reed, 2 m cable
67902-1-05	NPN (Sink) or PNP (Source) DC Reed, 5 m cable
67903-1-02	NPN (Sink) DC Solid State, 2 m cable
67903-1-05	NPN (Sink) DC Solid State, 5 m cable
67904-1-02	PNP (Source) DC Solid State, 2 m cable
67904-1-05	PNP (Source) DC Solid State, 5 m cable
67922-1	NPN (Sink) or PNP (Source) DC Reed, Quick Connect
67923-1	NPN (Sink) DC Solid State, Quick Connect
67924-1	PNP (Source) DC Solid State, Quick Connect
63549-02	2 meter Cordset with Quick Connect
63549-05	5 meter Cordset with Quick Connect

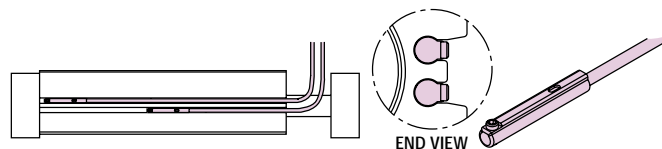

REED BENEFITS

- Available as 4.5 - 30 VDC model for simple interfacing to sequencers and programmable controllers.
- Can be used to directly drive some types of relays or valve solenoids within the switch specifications stated.

SPECIFICATIONS	67902 & 67922
OPERATING PRINCIPLE	Magnetic Reed
ACTUATED BY	Piston Magnet
INPUT VOLTAGE	4.5 - 30 VDC
OUTPUT TYPE	Contact Closure
CURRENT RATING	50 mA Max.
CONTACT RESISTANCE	.115 Ohm Max.
ENVIRONMENTAL	IP67
OPERATING TEMP.	-20° to 85°C

SIZE	REPEATABILITY	HYSTERESIS		BAND WIDTH	
		MAXIMUM	MINIMUM/MAXIMUM	MINIMUM/MAXIMUM	
08	± .005 [± .13]	.060 [1.5]	.260 / .450 [6.6 / 11.4]		
12	± .005 [± .13]	.060 [1.5]	.260 / .660 [6.6 / 16.8]		
16	± .005 [± .13]	.075 [1.9]	.340 / .440 [8.6 / 11.2]		
25	± .005 [± .13]	.070 [1.8]	.300 / .425 [7.6 / 10.8]		
32	± .005 [± .13]	.080 [2.0]	.290 / .640 [7.4 / 16.3]		

SOLID STATE BENEFITS

- Solid state switches afford long life. Constant amplitude output allows use with most digital logic systems.
- Switch circuitry protects against voltage surges and other electrical anomalies associated with operating systems.
- Excellent switch hysteresis characteristics and symmetry.
- Offered in 4.5 - 30 VDC current sinking and current sourcing versions for simple interfacing to electronic system controllers.

SPECIFICATIONS	67903 & 67923	67904 & 67924
OPERATING PRINCIPLE	Solid State	
ACTUATED BY	Piston Magnet	
INPUT VOLTAGE	4.5 - 30 VDC	
OUTPUT TYPE	NPN (Sink)	PNP (Source)
CURRENT RATING	50 mA. Max	
VOLTAGE DROP	.5 VDC	
SWITCH BURDEN	10 mA. Max.	
ENVIRONMENTAL	IP67	
OPERATING TEMP.	-20° to 85°C	

SIZE	REPEATABILITY	HYSTERESIS		BAND WIDTH	
		MAXIMUM	MINIMUM/MAXIMUM	MINIMUM/MAXIMUM	
08	± .005 [± .13]	.070 [1.8]	.255 / .550 [6.5 / 14.0]		
12	± .005 [± .13]	.069 [1.8]	.260 / .550 [6.6 / 14.0]		
16	± .007 [± .18]	.095 [2.4]	.330 / .510 [8.4 / 13.0]		
25	± .005 [± .13]	.080 [2.0]	.320 / .470 [8.1 / 11.9]		
32	± .005 [± .13]	.095 [2.4]	.280 / .580 [7.1 / 14.7]		

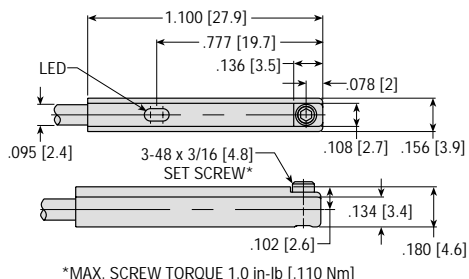

MALE QUICK CONNECT DETAIL

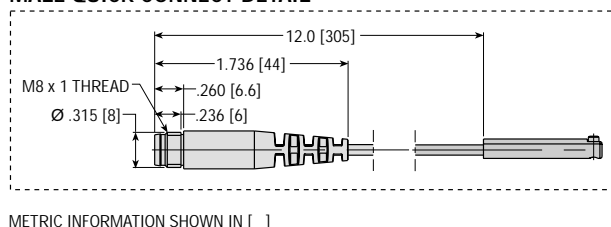

63549-xx CORDSET WITH FEMALE QUICK CONNECT

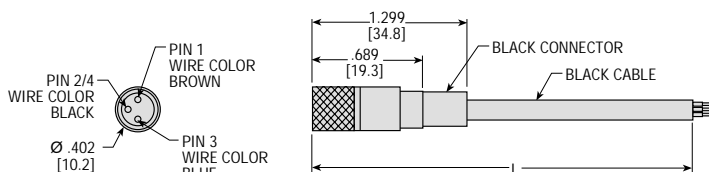

MODEL NO.	LETTER DIM.
	L
63549-02	78.74 [2 m]
63549-05	196.85 [5 m]

OPTIONS: SERIES SM SLIDES

SOLID STATE WIRING SCHEMATICS

MODEL NO. 67903-1 & 67923-1 - NPN (SINK)
INPUT: 4.5 - 30 VDC
LOAD CURRENT: 50 mA. MAX.
SWITCH HOUSING COLOR: BLACK
 (Bi-polar LED emits a yellow light)

CABLED MODEL 67903

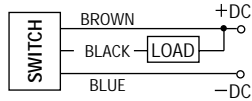

QUICK CONNECT MODEL 67923

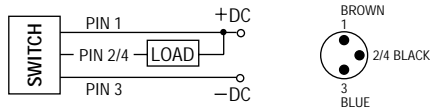

MODEL NO. 67904-1 & 67924-1 - PNP (SOURCE)
INPUT: 4.5-30 VDC
LOAD CURRENT: 50 mA. MAX.
SWITCH HOUSING COLOR: BLACK
 (Bi-polar LED emits a red light.)

CABLED MODEL 67904

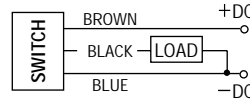

QUICK CONNECT MODEL 67924

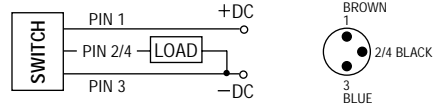

REED WIRING SCHEMATICS

MODEL NO. 67902-1 & 67922-1 - NPN (SINK) OR PNP (SOURCE)
INPUT: 4.5 - 30 VDC
LOAD CURRENT: 50 mA. MAX.
SWITCH HOUSING COLOR: BLACK
 (LED emits a red light)

CABLED MODEL 67902 - NPN (SINK)

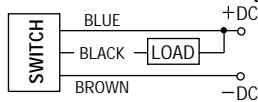

QUICK CONNECT MODEL 67922 - NPN (SINK)

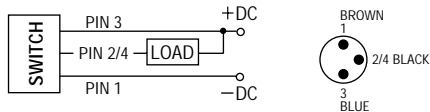

CABLED MODEL 67902 - PNP (SOURCE)

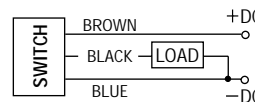

QUICK CONNECT MODEL 67922 - PNP (SOURCE)

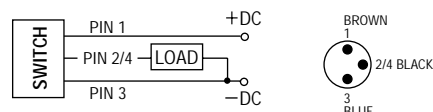

CORROSION RESISTANT COMPLETE SHAFTS

This option provides complete corrosion resistant coating on guide shafts for SMxx16, SMxx25 and SMxx32 units. This is for use in applications where the standard shaft ends may corrode. SMHx08 and SMHx12 units are completely corrosion resistant including the shafts as standard.

OPTIONS: SERIES SM SLIDES

UB55 PORTS IN SHAFTS LOCATED IN POSITION 5

UB66 PORTS IN SHAFTS LOCATED IN POSITION 6

These options provide porting in the shafts located in the desired position. The shaft closest to the ports in the saddle will always be considered the retracted port. SMxx25 & SMxx32 units include port adaptors to allow the use of 1/8 NPT [1/8 BSPP] fittings. Not available on SMxx08.



UNIT SIZE	STANDARD PORT IN SADDLE	STANDARD THREAD IN SHAFT	PORT ADAPTOR THREAD	A HEX	B LENGTH
12	10-32 [M5 x 0.8]	M3 x 0.5	M3 BARB	.197 [5]	.394 [10]
16	10-32 [M5 x 0.8]	10-32 [M5 x 0.8]	—	—	—
25	1/8 NPT [1/8 BSPP]	M8 x 1.25	1/8 NPT [1/8 BSPP]	.50 [13]	.551 [14]
32	1/8 NPT [1/8 BSPP]	M12 x 1.75	1/8 NPT [1/8 BSPP]	.625 [16]	.551 [14]

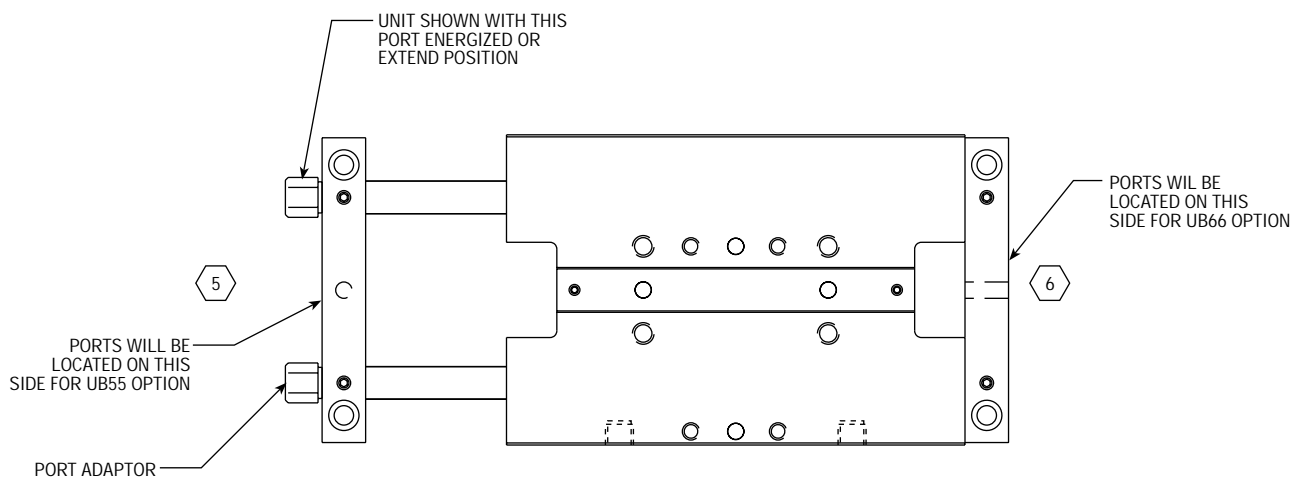

PORT ADAPTOR INFORMATION

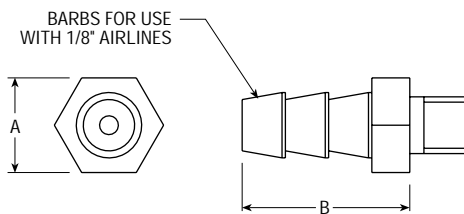

SIZE 12

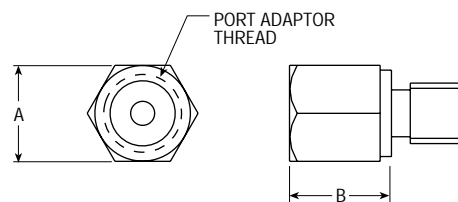

SIZES 25 AND 32

ACCESSORIES: SERIES SM SLIDES

MODULAR MOUNTING KITS

Modular design of the Series SM slide body allows Series STP Rail Slides to bolt and dowel together without the need for a transition plate. See chart for slide compatibility and hardware kits required. Each kit contains 2 dowel pins and 4 SHCS to mount the units together. PHD recommends that a -J3 option (transitional fit) be specified with the slide ordering data to allow the units to dowel together properly.

PRIMARY	SECONDARY	KIT NUMBERS	
		IMPERIAL	METRIC
SMxx08	STPDx08	71033	71034
SMxx12	STPDx12	71387	71388
SMxx16	STPDx16	71043	71044
SMxx25	STPDx25	71053	71054
SMxx32	STPDx32	CONSULT PHD	

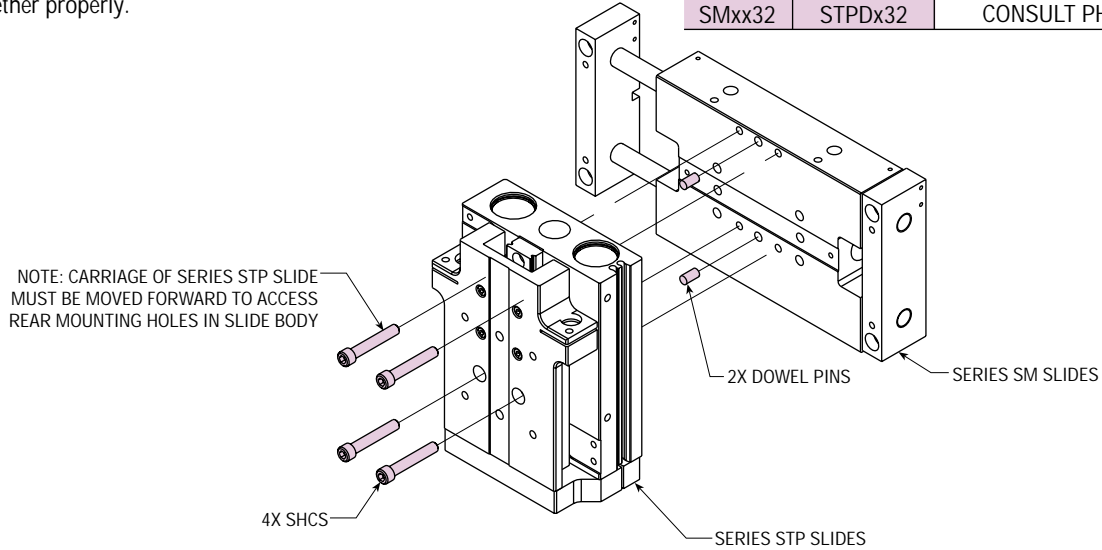

PROXIMITY SWITCH BRACKET & TARGET KIT (KIT #71032)

Each kit contains a bracket, target and hardware for mounting one 8 mm threaded proximity switch on an Series SMx Slide. Switches must be ordered separately. See switches section in PHD's main catalog for detailed switch information.

UNIT SIZE	A		B	
	in	mm	in	mm
08	.827	21	.354	9
12	.866	22	.433	11
16	.748	19	.472	12
25	.748	19	.669	17
32	.630	16	.787	20

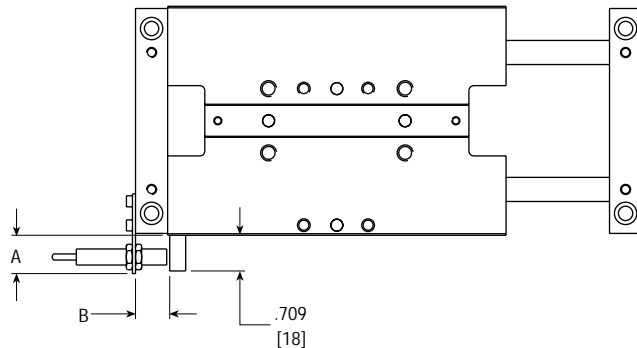
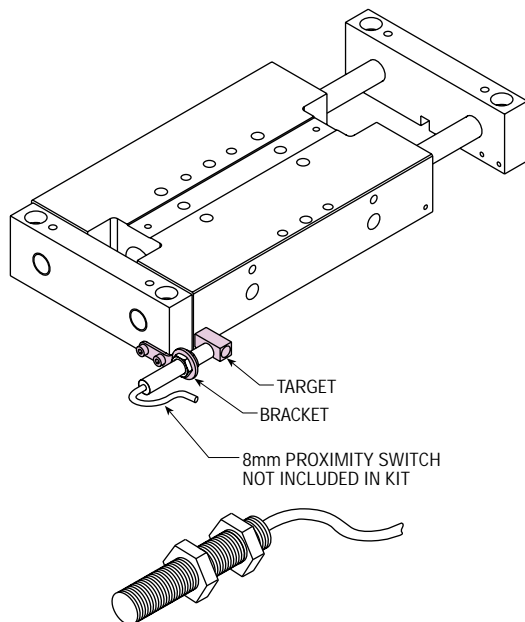

PART NO.	DESCRIPTION
51422-005-02	8 mm Inductive Proximity Switch NPN with 2 meter Cable
51422-006-02	8 mm Inductive Proximity Switch PNP with 2 meter Cable

See Switches and Sensors section of PHD's main catalog for switch details.

STOPPING CAPACITY: SERIES SM SLIDES

STOPPING CAPACITY SELECTION

To determine stopping capacity, calculate total moving weight. From Table 1, determine slide standard moving weight, add any additional weight adds due to options and add attached payload. This will be total moving weight W_{TM} .

Example: SMB125 x 2 -AE-AR with 10 lb load
[SMB525 x 50-AE-AR with 44.5 N load]

$$W_{TM} = 2.8 \text{ lb} + .34 \text{ lb} + .34 \text{ lb} + 10 \text{ lb} = 13.48 \text{ lb}$$

$$[12.5 \text{ N} + 1.5 \text{ N} + 1.5 \text{ N} + 44.5 \text{ N} = 60 \text{ N}]$$

Using the Kinetic Energy Graphs below, plot the total moving weight against impact velocity. If the value plotted is below the curve, then shock pads are an adequate deceleration method. If it is above the curve, hydraulic shock absorbers are required.

To determine the correct hydraulic shock absorber, complete the calculations on the next page.

TABLE 1

SIZE	TRAVEL		STANDARD MOVING WEIGHT		EFFECTIVE PISTON AREA	
	in	mm	lb	N	in ²	mm ²
08	1	25	0.34	1.5	0.12	75
	2	50	0.44	2.0		
	3	75	0.53	2.4		
12	1	25	0.85	3.8	0.27	172
	2-1/2	60	1.1	4.9		
	4	100	1.3	5.8		
16	1-1/2	38	1.7	7.6	0.47	302
	3	75	2.0	8.9		
	5	125	2.4	10.7		
25	2	50	3.5	15.6	1.17	756
	4	100	4.4	19.6		
	6	150	5.1	22.7		
32	3	75	5.6	24.9	1.87	1206
	6	150	7.4	32.9		

MAXIMUM ALLOWABLE KINETIC ENERGY

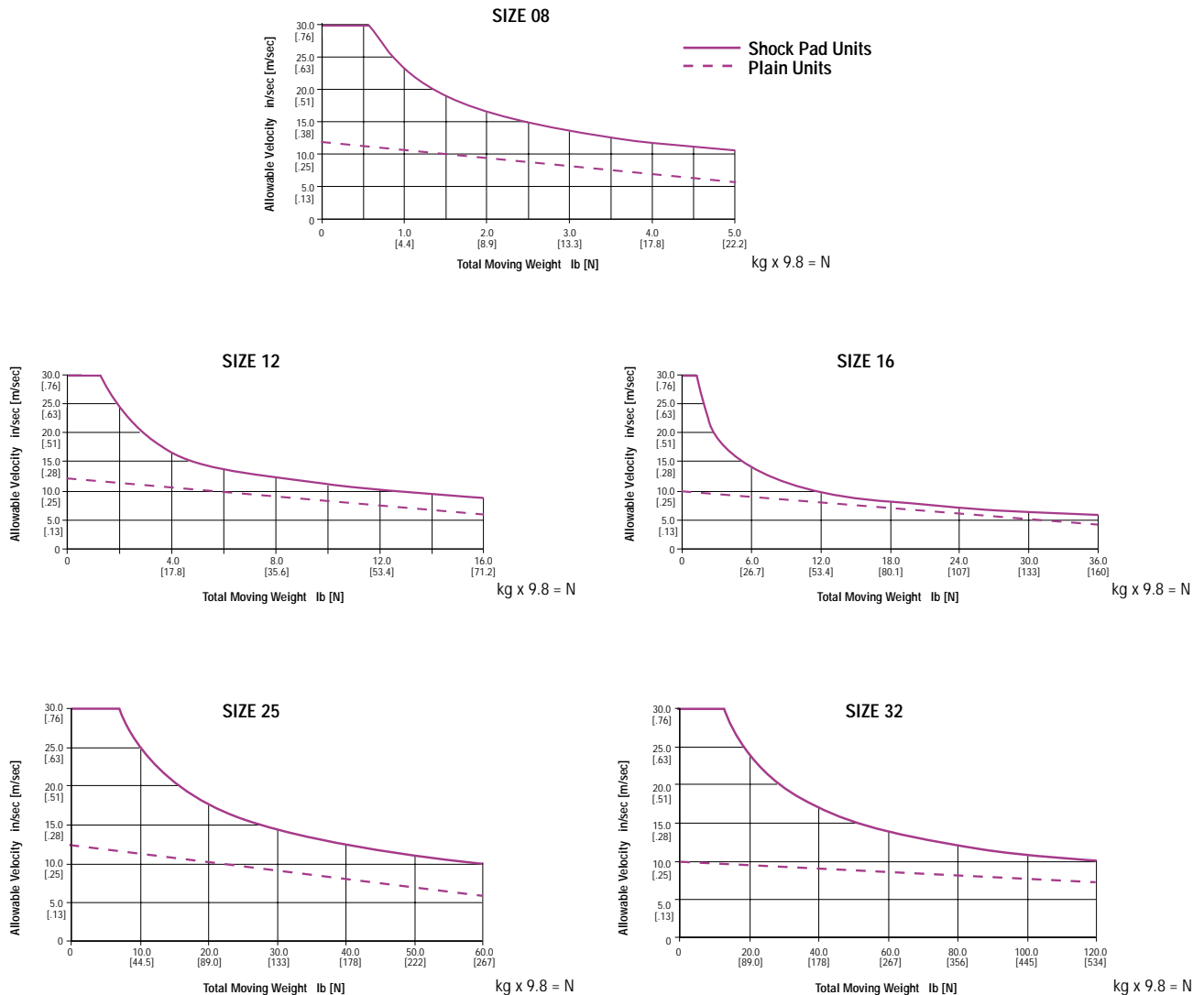

SHOCK ABSORBER SELECTION GUIDE: SERIES SM SLIDES

PHD SHOCK ABSORBER SPECIFICATIONS CHART

SIZE	PHD SHOCK ABSORBER NO.	STROKE		THREAD TYPE	E _T TOTAL ENERGY PER CYCLE		E _T C TOTAL ENERGY PER HOUR		F _G MAX PROPELLING FORCE	
		in	m		in-lb	Nm	in-lb	Nm	lb	N
08	68149-01-x	.210	.0053	M8 x 1	25	2.8	50,000	5654	45	200
12	68149-02-x	.230	.0058	M8 x 1	25	2.8	50,000	5654	45	200
16	68015-01-x	.240	.0061	M10 x 1	50	5.7	110,000	12439	80	356
25	67127-01-x	.448	.0114	M14 x 1.5	150	17.0	260,000	29400	200	890
32	71451-01-x	.720	.0183	M20 x 1.5	240	27.1	400,000	45231	280	1245

SYMBOLS DEFINITIONS

- C = Number of cycles per hour
- D = Cylinder bore diameter inch [mm]
- E_k = Kinetic energy in-lb [Nm]
- E_T = Total energy per cycle, E_k + E_w in-lb [Nm]
- E_TC = Total energy per hour in-lb/hr [Nm/hr]
- E_w = Work or drive energy in-lb [Nm]
- F_D = Propelling force lb [N]
- F_G = Max Propelling force lb [N]
- P = Operating pressure psi [bar]
- S = Stroke of shock absorber inch [m]
- V = Impact velocity in/sec [m/sec]
- W_{TM} = Total moving weight lb [N or kg]

SHOCK ABSORBER SIZING CALCULATION:

Follow the next six steps to size shock absorbers.

STEP 1: Identify the following parameters. These must be known for all energy absorption calculations. Variations or additional information may be required in some cases.

- A. The total moving weight (W_{TM}) to be stopped. (completed from prior page)
- B. The slide velocity (V) at impact with the shock absorber.
- C. Number of cycles per hour.
- D. Orientation of the application's motion (i.e. horizontal or vertical application). See page 6.
- E. Operating pressure

STEP 2: Calculate the kinetic energy of the total moving weight.

$$E_k \text{ (in-lb)} = .5 \times \frac{W_{TM} \times V^2}{386} \quad E_k \text{ (Nm)} = .5 \times \frac{W_{TM} \times V^2}{9.8}$$

or

Note: W_{TM} in kg mass may be substituted for $\frac{W_{TM}}{9.8}$

$$E_k \text{ (Nm)} = .5 \times W_{TM} \times V^2$$

STEP 3: Calculate the propelling force (F_D) for both extend and retract. Refer to previous page for Effective Piston Areas.

Horizontal application: F_D = Effective Piston Area x P

Vertical application: F_D = (Effective Piston Area x P) ± W_{TM}

+ indicates working with gravity, - indicates working against gravity

Note: when using mm² and bar units, it will be necessary to multiply the Effective Piston Area x P by a factor of .1 to obtain the correct unit of measure.

Use Shock Absorber Specification Chart to verify that the selected unit has an F_G capacity greater than the value just calculated. If not, select a larger shock absorber or slide.

Calculate the work energy input (E_w = F_D x S) using the travel of the shock absorber selected.

STEP 4: Calculate the total energy. E_T = E_k + E_w

Use Shock Absorber Specification Chart to verify that the selected unit has an E_T capacity greater than the value just calculated. If not, select a larger shock absorber or slide.

STEP 5: Calculate the total energy that must be absorbed per hour (E_TC). E_TC = E_T x C

Use Shock Absorber Specification Chart to verify that the selected unit has an E_TC capacity greater than the value just calculated. If not, select a larger shock absorber or slide.

STEP 6: Determine the damping constant for the selected shock absorber. Using the appropriate Shock Absorber Performance Graph, locate the intersection point for impact velocity (V) and total energy (E_T). The area (-1, -2 -3, or -4) that the point falls in is the correct damping constant for the application.

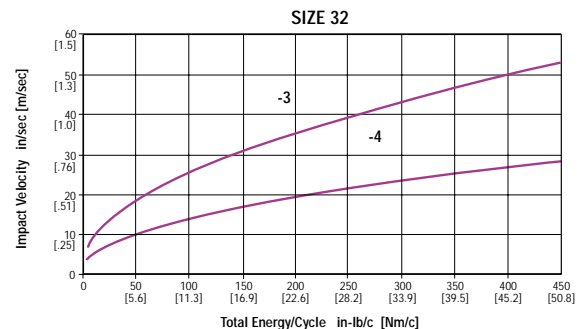
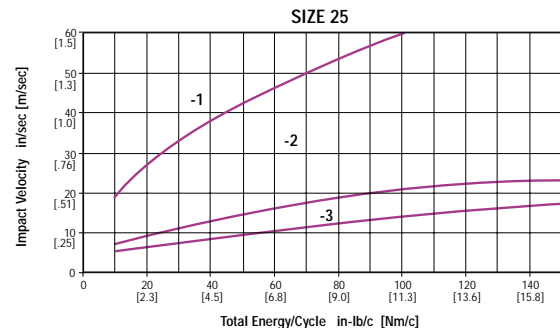
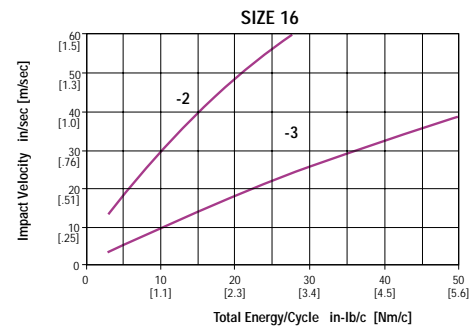
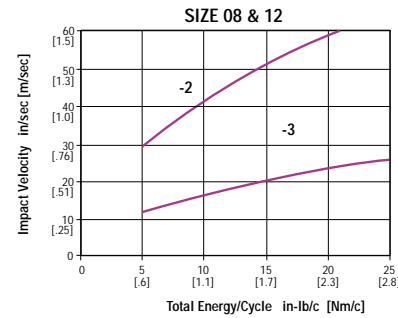

SLIDE SIZING EXAMPLE: SERIES SM SLIDES

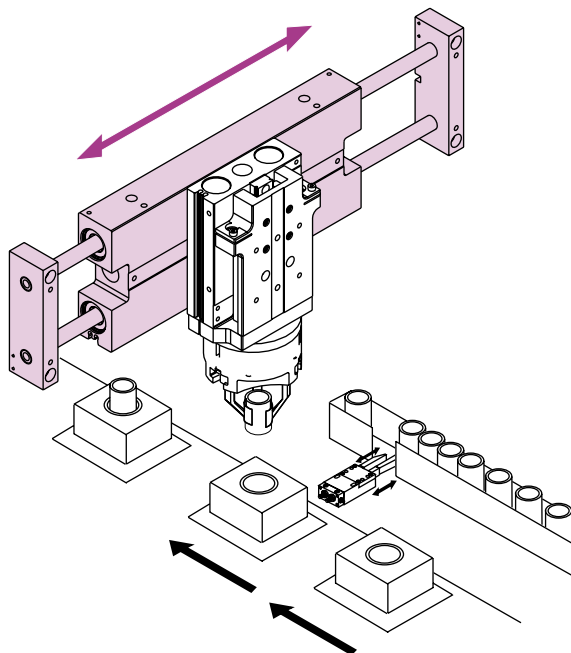

HORIZONTAL APPLICATION ON EDGE

STEP 1: Determine Application Data

Pick and place application as shown

Total Weight of vertical slide = 4.8 lb [21.4 N]

Total Weight of gripper and tooling = .6 lb [2.7 N]

Total Weight of gripped object = .1 lb [.4 N]

Operating Pressure = 87 psi [6 bar]

Required Travel = 5" [125 mm]

Bushings = Polymer

Cycle/hours = 1800

Velocity = 30 in/sec [.76 m/sec] Max

Offset from center of slide (CG) = 1.25 in [31.75 mm]

Travel adjustment or shock absorbers required

STEP 2: Determine the Total Weight of the system

Total Weight = 4.8 + .6 + .1 = 5.5 lb [24.5 N]

STEP 3: Determine the moment load of the system

Refer to the Roll Load Calculations to determine minimum size of actuator required.

$L = C / (D+B)$, where L = Load lb [N], D = CG Distance,
 B, C = Constants obtained from Roll table

Minimum Travel required is 5", first check for SMHx16

$L = 13 [1468] / (1.25 [31.75] + .969 [24.6]) = 5.86 \text{ lb} [26 \text{ N}]$

Since 5.86 lb [26 N] > applied load then SMHx16 would be sufficient.

STEP 4: Refer to page 6 for thrust capacity calculation if needed.

STEP 5: Refer to PHD's Selection Software for deflection calculations if needed

STEP 6: Calculate Stopping Capacity

Using the total moving weight and the velocity, review the kinetic energy graphs. Since the plotted value for shock pads falls outside the curves, shock absorbers are required.

See Shock Absorber Selection Guide for detailed instructions.

W_{TM} = Total weight of system + moving weight

$W_{TM} = 5.5 [24.5] + 2.4 [10.7] = 7.9 \text{ lb} [35.2 \text{ N}]$

$E_K = .5 \times W_{TM} \times V^2 / 386 = 9.2 \text{ in-lb} [1.04 \text{ Nm}]$

F_D = Effective Piston Area x Operating Pressure

$F_D = .47 \text{ in}^2 [302 \text{ mm}^2] \times 87 \text{ psi} [6 \text{ bar}] = 41 \text{ lb} [181 \text{ N}]$

Selection is OK since $F_D < 80$

$E_w = F_D \times S = 41 [181] \times .24 [.0061] = 9.8 \text{ in-lb} [1.1 \text{ Nm}]$

$E_T = E_K + E_w = 9.2 [1.04] + 9.8 [1.1] = 19 \text{ in-lb} [2.15 \text{ Nm}]$

Selection is OK since $E_T < 50 \text{ in-lb} [5.7 \text{ Nm}]$

$E_T C = E_T \times C = 19 [2.15] \times 1800 = 34200 [3870]$

Selection is OK since $E_T C < 110,000 [12439]$

Refer to Shock Absorber graphs to select the appropriate damping constant which would be -3.

STEP 7: Generate Slide Model Number

SMH116 x 5 - NE3 - NR3 for Imperial

SMH516 x 125 - NE3 - NR3 for Metric

EXPLODED VIEW: SERIES SM SLIDE SLIDES

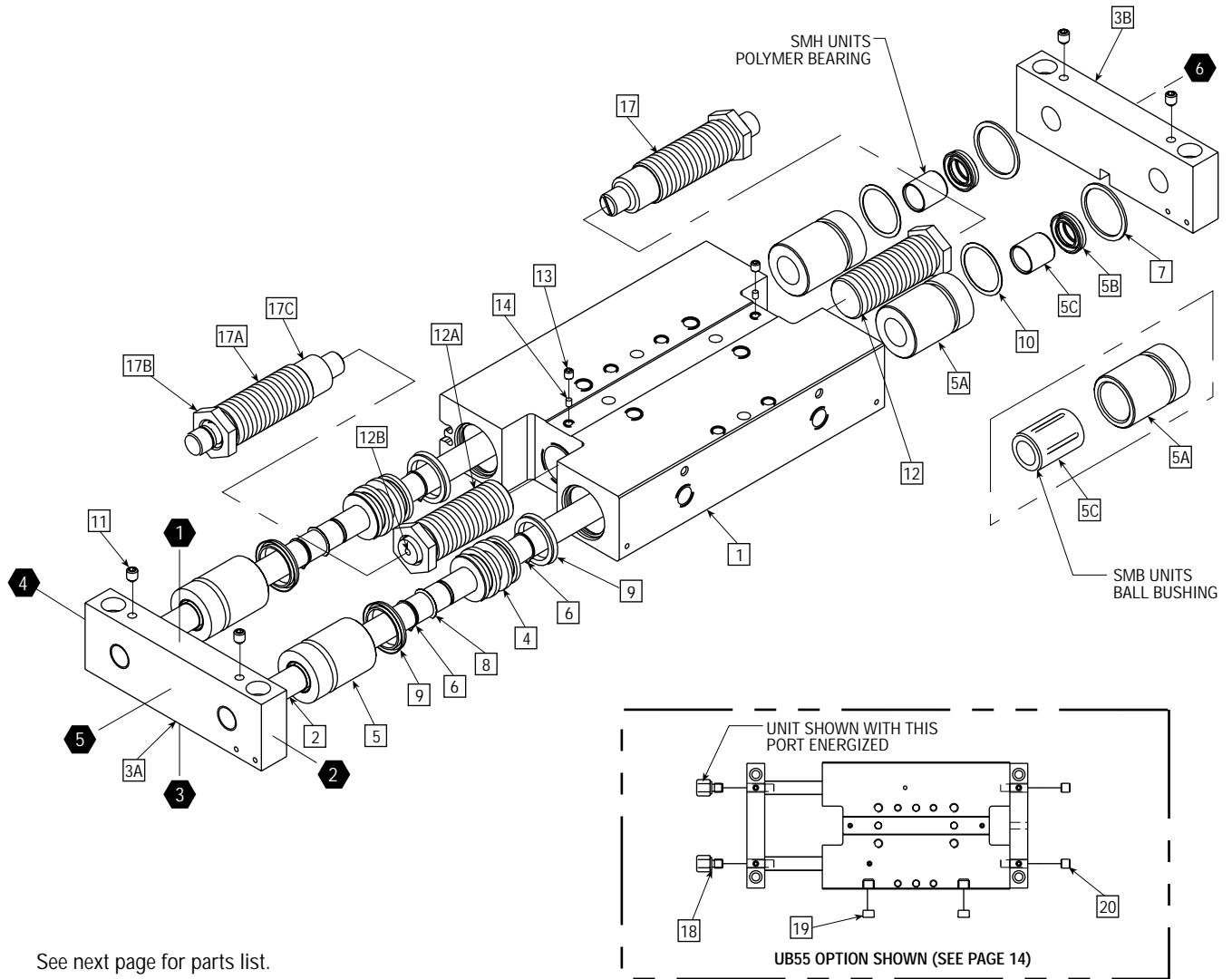

See next page for parts list.

PARTS LIST & REPAIR KITS: SERIES SM SLIDES

KEY	PART DESCRIPTION	SIZE 08	SIZE 12	SIZE 16	SIZE 25	SIZE 32	
1	Body Assembly	Full unit description required					
2	Shaft	Full unit description required					
3A	Dowel Tool Plate	68071-105	71373-105	67966-105	67074-105	71433-105	
3B	Slotted Dowel Tool Plate	68072-105	71374-105	67967-105	67075-105	71434-105	
4	Piston	Standard	—	71377-0	67981-0	67088-0	71437-0
		Magnet	—	71377-1	67981-1	67088-1	71437-1
5	Cartridge Assembly	SMH	68102-03-1	70727-03-1	68005-04-1	67133-04-1	70927-03-1
		SMB	—	70727-04-1	68005-05-1	67133-03-1	70927-04-1
5A	Rod Seal Cartridge	Sold as part of cartridge assembly					
5B	Rod Seal	Sold as part of cartridge assembly and/or seal kit					
5C	Bushing	Sold as part of cartridge assembly					
6	Piston Retaining Ring	Sold as part of repair kit					
7	Cartridge Retaining Ring	Sold as part of repair kit					
8	Shaft Piston Seal	Sold as part of repair kit					
9	Piston Seal	Sold as part of repair kit					
10	Wear Ring	Sold as part of seal kit					
11	Set Screw	Sold as part of repair kit					
OPTIONAL PARTS							
12	Travel Adjustment Assembly	Sold as part of travel adjustment kit					
12A	Travel Adjustment Screw	Sold as part of travel adjustment kit					
12B	Shock Pad	Sold as part of travel adjustment kit					
13	Set Screw	Sold as part of travel adjustment and shock mounting kit					
14	Locking Material	Sold as part of travel adjustment and shock mounting kit					
17	Shock Holder Assembly	Sold as part of shock mounting kit					
17A	Shock Holder	Sold as part of shock mounting kit					
17B	Shock Absorber Assembly	Sold as part of shock mounting kit					
17C	Locking Sleeve	Sold as part of shock mounting kit					
18	Fitting Adaptor	Imperial	—	18056	—	67105-01	71445-01
		Metric	—	18056	—	67105-02	71445-02
19	Port Plug	—	53735-001	53735-001	1992-001-03	1992-001-03	
20	Set Screw	—	64364-016	64364-010	64364-006	64364-047	

KITS

KIT DESCRIPTION	QTY	KIT NUMBER					
		SIZE 08	SIZE 12	SIZE 16	SIZE 25	SIZE 32	
Repair Kit	1	71031-1	71386-1	71041-1	71051-1	71446-1	
8 mm Proximity Kit	1*	71032	71032	71032	71032	71032	
Modular Kit	1	Imperial	71033	71387	71043	71053	71447
		Metric	71034	71388	71044	71054	71448
Travel Adjustment Kit	1*	71035	71389	71045	71055	71449	
Shock Mounting Kit	1*	71036-x	71390-x	71046-x	71056-x	71450-x	

* Indicates 1 kit required for each position of adjustment.

x indicates the damping constant of the shock absorber (-1, -2, -3)

PHD, Inc.
9009 Clubridge Drive
P.O. Box 9070, Fort Wayne, Indiana 46899 U.S.A.
Phone (260) 747-6151 • Fax (260) 747-6754

PHD GmbH
Arnold-Sommerfeld-Ring 2
D-52499 Baesweiler GERMANY
Phone 02401-805 230 • Fax 02401-805 232