

ISO STANDARD 6431, 6432, AND VDMA 24562 SERIES CV CYLINDERS

*Series CV are full
feature cylinders providing
exceptional performance.*



**AN INDUSTRY STANDARD
WITH MUCH MORE!**



DOUBLE ROD ENDS



RODLOK®



HUSHCONTROL®



3 POSITION

INDEX:
Product Selection Guide
Pages 1D-2 and 1D-3

Ordering Data
Page 1D-4

Benefits
Page 1D-5

Dimensions
Pages 1D-6 and 1D-7

Engineering Data
Pages 1D-8 to 1D-12

Options
Pages 1D-13 to 1D-18

Mounting Styles
Pages 1D-19 and 1D-20

Mounting Accessories
Pages 1D-21 to 1D-29

Application Examples
Pages 1D-30

PRODUCT SELECTION GUIDE: SERIES CV CYLINDERS

1D

SERIES CVC CYLINDERS 20 & 25 mm ISO 6432



- Available in bore sizes 20 mm and 25 mm. Conforms to ISO 6432 customer interface and overall unit length when specified with optional -P or -Q mounting.

SERIES CVB CYLINDERS 20 & 25 mm



- Available in bore sizes 20 mm and 25 mm. Custom interface conforms to ISO 6432 specifications.

SERIES CVA CYLINDERS 32-100 mm ISO 6431



- Standard 32 mm through 100 mm bore units conform to ISO 6431 and VDMA 24562 specifications.

SERIES CV 3 position CYLINDERS



- Series CVA and CVB are available as 3 position units.



Mounting Accessories
page 1D-21



Rodlok®
page 1D-14



Hushcontrol®
page 1D-5

PHD SOLUTIONS

Why Buy PHD?

Because PHD will provide the support, software, and delivery you need!



Unique application designs require unique components. With over 30 years of experience, our Custom Products team welcomes special requests for unique products, regardless of quantity or frequency of order. Call **1-800-624-8511** to request a quote.



PHD distributors are factory trained, application oriented, and carry a wide range of supporting product lines. Your local distributor will take the time to thoroughly analyze and assess your specific needs.

Contact your local distributor today for the full story including a working product demonstration at your site.



PHD's engineering software provides powerful design and selection tools at your fingertips. The software eliminates risk and simplifies your design process and component selection, while offering significant time savings.



Even with the wide range of options offered on PHD products, shipping time in most cases is one to four working days. In today's fast-paced competitive markets, we understand the need for quick turnaround. With a track record of 98% on-time shipments, you can be assured of prompt delivery. And if you find yourself in an emergency situation, expedited service is also available.

REAR PIVOT MOUNTING STYLES

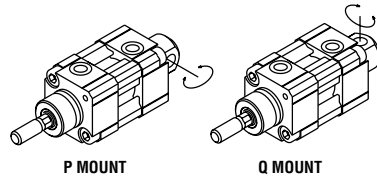

**METRIC STROKE (CVx5)
STANDARD STROKE LENGTHS**
(15 mm = minimum stroke
in 5 mm increments)

BORE [mm]	MAXIMUM STROKE [mm]
CVC20	500
CVC25	500
CVB20	750
CVB25	750
32	1000
40	1000
50	1000
63	1000
80	1000
100	1000

Contact PHD for shorter or longer strokes.

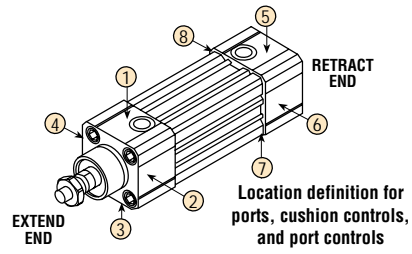

TO ORDER, SPECIFY:
Product, Series, Type, Design No.,
Mounting style, Bore size, Stroke,
and any Options.

MOUNTING STYLE
P - Rear pivot in position 5
Q - Rear pivot in position 6
V - Standard mounting
4 female threads
each end per ISO
6431/VDMA 24562
& ISO 6432*
(-P and -Q available on
20 & 25 mm bores only)

CUSHION CONTROL
DB - Cushion Controls
Both Ends
DE - Cushion Control
Extend Only
DR - Cushion Control
Retract Only
Standard cushion control
locations are 1 & 5. See
note 7. See page 1D-13
for more information.

OPTIONAL PORT LOCATION
UB00 - Ports on all sides, both ends (Not available
with Port Controls on same end) Contact PHD For
other combinations. Standard port locations are 1 & 5.
See page 1D-18 to specify other locations.

TYPE
S - Single Rod, double
acting (Standard)
D - Double Rod, ⊕
double acting (Not
available on 3
position units.)

**THREE
POSITION UNIT**
(Specify only
if needed)

PRODUCT
C - Cylinder

MODEL NUMBER C VB S E 5 P 20 x 25 - 25 - PB DB - UB00 - M-Z1

**SERIES
SIZES 20 & 25 mm ONLY**
VB - ISO 6432
150 psi [10 bar] Air
VC - ISO 6432
150 psi [10 bar] Air

**SERIES
SIZES 32-100 mm**
VA - VDMA 24562
ISO 6431
150 psi [10 bar] Air

DESIGN NO.
5 - Metric

BORE SIZE

mm	BORE		PISTON AREA	
	in	sq mm	sq in	
20	.787	314	.486	
25	.984	491	.760	
32	1.26	804	1.25	
40	1.58	1257	1.95	
50	1.97	1963	3.05	
63	2.48	3117	4.83	
80	3.15	5027	7.79	
100	3.94	7854	12.17	

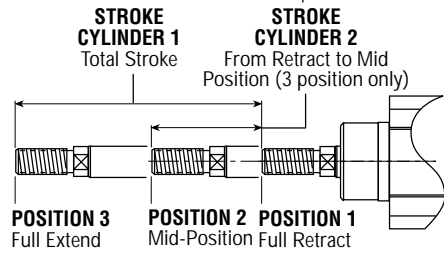

POSITION 3 Full Extend
POSITION 2 Mid-Position Full Retract
POSITION 1

PORT CONTROL ⊕
**BUILT-IN METER OUT
FLOW CONTROL VALVE**
PB - Port Controls Both Ends
PE - Port Control Extend Only
PR - Port Control Retract Only
Standard port control
locations are 1 & 5. See
note 7. See page 1D-17 for
more information.

CYLINDER OPTIONS
F22 - 4 Wrench Flats on Rod
F44 - No Wrench Flats on Rod ⊕
H46 - Rodlok® ready cylinder (CVAS only) ⊕
H47 - Rodlok® unit includes locking device ⊕
Adaptor and Cylinder preassembled
(CVAS only)
K_ - Extra Rod Extension ⊕
in 5 mm increments. Length code
is K5 = 5 mm, K15 = 15 mm, etc.
L9 - NPT Ports ⊕
M - Magnetic piston for use with
PHD Miniature Reed and
Magnetoresistive Switches
T44 - Female Rod End Undersized Thread ⊕
T55 - Plain Rod End ⊕
TEE - Male Rod with Oversized Thread (CVAx only) ⊕
Z1 - Corrosion Resistant, chrome-plated
Stainless Steel Rod, and appropriate
coating on ferrous parts.

- NOTES:**
- Z1 option may have reduced cylinder performance due to chrome-plated stainless steel rod in place of chrome-plated alloy steel.
 - H47 is not available in -Z1.
 - *For mounting accessories and dimensions, see pages 1D-21 to 1D-29.
 - ⊕ Marked options provide additional cylinder flexibility, but do not dimensionally comply with the ISO 6431/VDMA 24562 or ISO 6432 specifications.
 - ISO cylinders are of metric design. Imperial dimensions and specifications are provided for convenience.
 - See page 1D-16 for switch information.
 - On 3 position units, cushion control, and Port Controls are available in locations 1 and 5 only.

**Options may affect unit length.
See unit dimension and options
pages for adders.**

BENEFITS: SERIES CV CYLINDERS

- **The HUSHCONTROL® Advantage**
 Units specified with the Hushcontrol® Advantage provide superb speed and deceleration control and environmentally friendly noise levels.
- Standard 32 mm through 100 mm bore units conform to ISO 6431 and VDMA 24562 specifications. Sizes 20 mm and 25 mm bore conform to ISO 6432 for customer interface and mounting dimensions.
- Available in 8 bore sizes from 20 mm to 100 mm to fit a wide range of applications. Available in standard stroke lengths up to 1000 mm on CVA units, 750 mm on CVB units, and 500 mm on CVC units.
- A wide range of mounting accessories provides ease of design into application.
- Both standard and corrosion resistant piston rods have hard chrome plating for maximum life and durability.
- The versatile design allows flexibility for custom modifications to meet your needs.
- Internal shock pads are standard on all sizes, eliminating metal to metal contact.
- Wide range of options, including NPT ports, provides easy selection of cylinders to meet your exact needs.
- Optional Rodlok® securely holds a static piston rod in place at any point of stroke desired. Ideal for applications where rod drift is unacceptable due to system leakage, line rupture, or power loss.
- Ports, cushion controls, and port controls are available in any combination on any side of the head (extend end) and cap (retract end).
- Optional PHD proximity switches mount easily on any side of the cylinder in the integral switch slots. No brackets are required for switch mounting.
- Cylinders, including port and cushion controls are easily field repairable, maximizing your investment.

SPECIFICATIONS	CVA & CVB	CVC
WORKING PRESSURE	7.5 psi min. - 150 psi max. [0.5 bar min. - 10 bar max.]	10 psi min. - 150 psi max. [0.67 bar min. - 10 bar max.]
LUBRICATION	Permanent for Non-Lube Air or Lubricated Air	
HEADS & CAPS	Anodized Aluminum Alloy	
CYLINDER TUBE	Anodized Aluminum Alloy	
PISTON ROD	Hard Chrome-Plated Steel or Hard Chrome-Plated Stainless Steel	
ROD BEARING	Internally Lubricated Engineered Polymer	
PISTON SEALS	Long Life Urethane Material	Long Life Nitrile Material
ROD SEALS	Long Life Urethane Material	



featuring..

The HUSHCONTROL® Advantage (-PB, -DB)

Only PHD Series CV Cylinders are offered with the Hushcontrol® Advantage. Hushcontrol® is achieved when optional cushions and Port Controls® are ordered with the standard shock pads. This combination provides:

- Superior speed and deceleration control of piston rod and attached loads.
- Significantly lowers noise levels even at high cycle speeds.

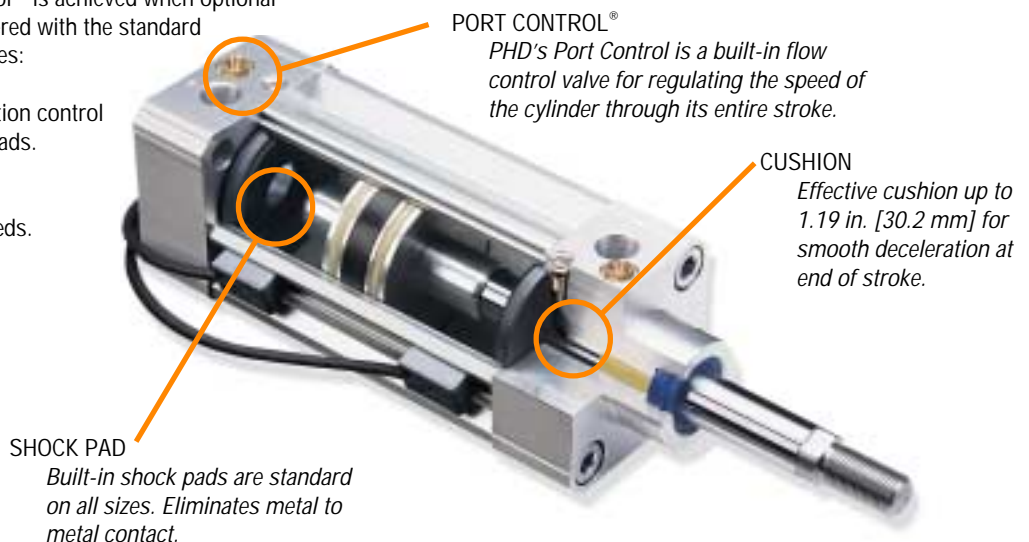

DIMENSIONS: SERIES CV CYLINDERS

SIZES 20 & 25 mm

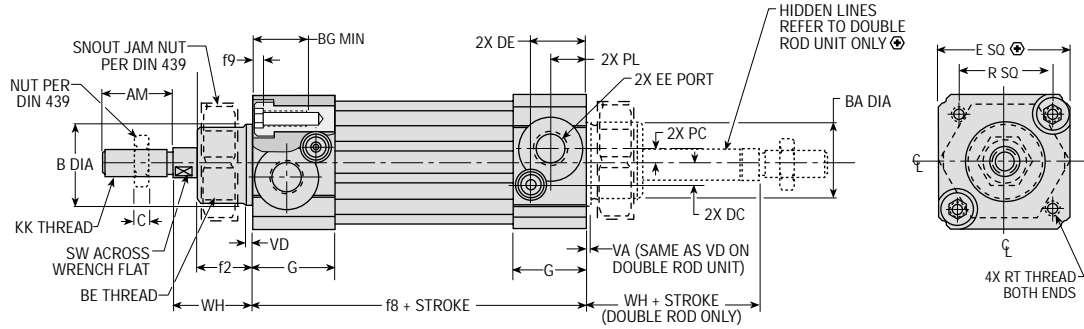
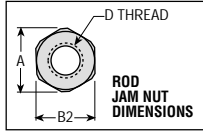
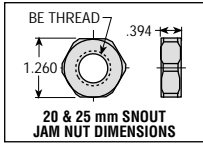

3 POSITION

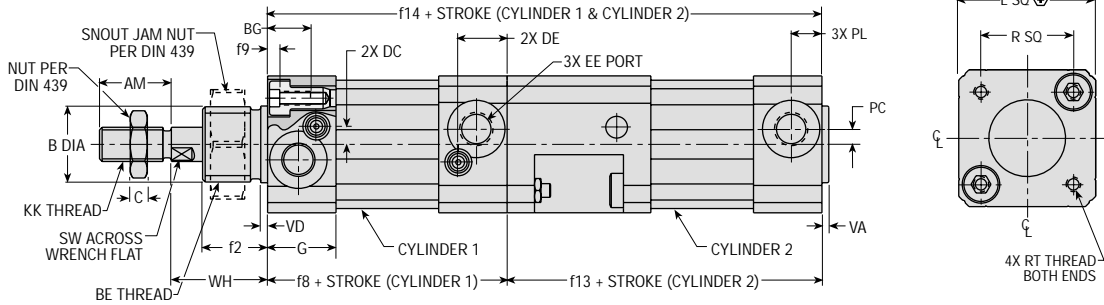

SIZES 32-100 mm

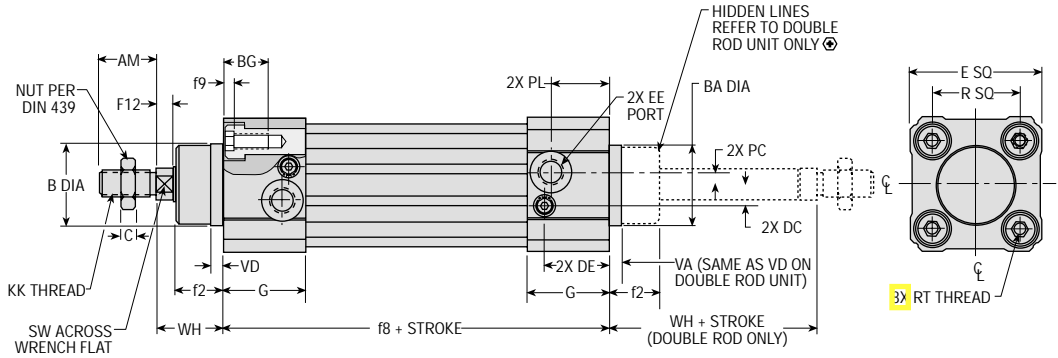
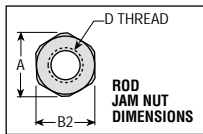

3 POSITION

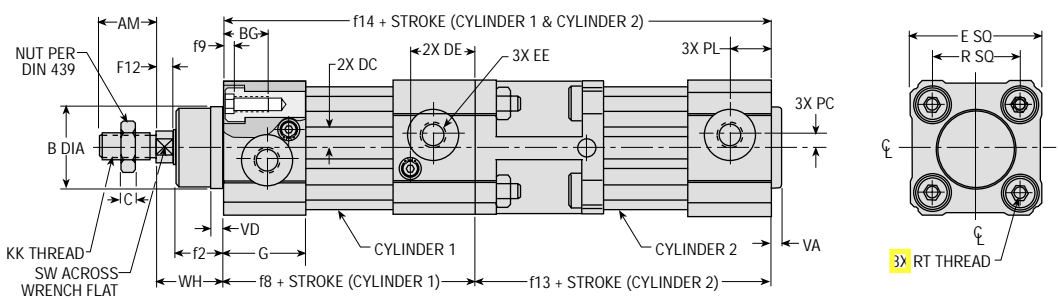

DIMENSIONS: SERIES CV CYLINDERS

LETTER DIM	BORE SIZE															
	20 mm		25 mm		32 mm		40 mm		50 mm		63 mm		80 mm		100 mm	
	in	mm	in	mm	in	mm	in	mm	in	mm	in	mm	in	mm	in	mm
A min	—	—	—	—	.744	18.9	.831	21.1	1.053	26.75	1.053	26.75	1.297	32.95	1.297	32.95
AM	.748	19.0	.827	21.0	.827	21.0	.906	23.0	1.220	31.0	1.220	31.0	1.535	39.0	1.535	39.0
B	.866	22.0	.866	22.0	1.181	30.0	1.378	35.0	1.575	40.0	1.772	45.0	1.772	45.0	2.165	55.0
B2	.512	13.0	.669	17.0	.669	17.0	.748	19.0	.945	24.0	.945	24.0	1.181	30.0	1.181	30.0
BA	.866	22.0	.866	22.0	1.181	30.0	1.378	35.0	1.575	40.0	1.772	45.0	1.772	45.0	2.165	55.0
BE	M22 x 1.5		M22 x 1.5		—		—		—		—		—		—	
BG min	.472	12.0	.472	12.0	.709	18.0	.709	18.0	.787	20.0	.787	20.0	.787	20.0	.787	20.0
C	.157	4.0	.197	5.0	.197	5.0	.236	6.0	.315	8.0	.315	8.0	.394	10.0	.394	10.0
D	M8 x 1.25		M10 x 1.25		M10 x 1.25		M12 x 1.25		M16 x 1.5		M16 x 1.5		M20 x 1.5		M20 x 1.5	
DC	.189	4.8	.205	5.2	.276	7.0	.374	9.5	.354	9.0	.354	9.0	.591	15.0	.630	16.0
DE	.583	14.8	.559	14.2	.965	24.5	1.083	27.5	1.004	25.5	1.201	30.5	1.181	30.0	1.339	34.0
E	1.457	37.0	1.575	40.0	1.949	49.5	2.205	56.0	2.697	68.5	3.150	80.0	3.858	98.0	4.528	115.0
EE PORT*	G 1/8		G 1/8		G 1/8		G 1/4		G 1/4		G 3/8		G 3/8		G 1/2	
EE DEPTH	.315	8.0	.315	8.0	.315	8.0	.354	9.0	.354	9.0	.472	12.0	.472	12.0	.551	14.0
f2	.669	17.0	.748	19.0	.728	18.5	.807	20.5	1.083	27.5	1.083	27.5	1.319	33.5	1.437	36.5
f8	2.323*	59.0*	2.520*	64.0*	3.701	94.0	4.134	105.0	4.173	106.0	4.764	121.0	5.039	128.0	5.433	138.0
f9	.142	3.6	.142	3.6	.165	4.2	.169	4.3	.224	5.7	.224	5.7	.268	6.8	.268	6.8
f12	—	—	—	—	.236	6.0	.256	6.5	.315	8.0	.315	8.0	.394	10.0	.394	10.0
f13	3.504	89.0	3.622	92.0	4.370	111.0	4.823	122.5	5.728	145.5	6.181	157.0	6.772	172.0	7.008	178.0
f14	6.142	156.0	6.378	162.0	8.071	205.0	8.957	227.5	9.902	251.5	10.945	278.0	11.811	300.0	12.441	316.0
G	.787	20.0	.787	20.0	1.220	31.0	1.358	34.5	1.358	34.5	1.496	38.0	1.496	38.0	1.654	42.0
KK	M8 x 1.25		M10 x 1.25		M10 x 1.25		M12 x 1.25		M16 x 1.5		M16 x 1.5		M20 x 1.5		M20 x 1.5	
PC	.165	4.2	.177	4.5	.197	5.0	.236	6.0	.236	6.0	.394	10.0	.394	10.0	.472	12.0
PL	.354	9.0	.354	9.0	.630	16.0	.728	18.5	.728	18.5	.787	20.0	.709	18.0	.866	22.0
R	1.024	26.0	1.063	27.0	1.280	32.5	1.496	38.0	1.831	46.5	2.224	56.5	2.835	72.0	3.504	89.0
RT	M4 x 0.7		M4 x 0.7		M6 x 1		M6 x 1		M8 x 1.25		M8 x 1.25		M10 x 1.5		M10 x 1.5	
SW	.276	7.0	.315	8.0	.394	10.0	.512	13.0	.630	16.0	.630	16.0	.827	21.0	.827	21.0
VA	.079	2.0	.079	2.0	.157	4.0	.157	4.0	.157	4.0	.157	4.0	.157	4.0	.157	4.0
VD	.079	2.0	.079	2.0	.177	4.5	.177	4.5	.177	4.5	.177	4.5	.177	4.5	.177	4.5
WH	.945	24.0	1.102	28.0	1.024	26.0	1.181	30.0	1.457	37.0	1.457	37.0	1.811	46.0	2.008	51.0

NOTES:

- 1) Unless otherwise dimensioned, mounting hole patterns are centered on the cylinder.
- 2) Ports and cushions may appear on either side of the cylinder centerline based on option combinations.
- 3) Dimensions shown are for CVC units. Add to f8 dimension .315 in [8 mm] for CVB20 and .236 in [6 mm] for CVB25.
- 4) *All units, except port with port control on same side, comply with DIN 3852 part 2 port specifications for short stud and large sealing surface. See port control option sheet for port and port control dimensions on units with ports and port controls on the same side.
- 5) ☉ This option does not dimensionally comply with the ISO 6432 specification.
- 6) Kit part numbers are available upon request.

ENGINEERING DATA: SERIES CV CYLINDERS

PRESSURE RATINGS

All Series CVA and CVB Cylinders have an operating pressure range of 7.5 psi minimum to 150 psi maximum [0.5 to 10 bar]. Pressure range for CVC units is 10 psi minimum to 150 psi maximum [0.67 to 10 bar].

SEALS

Series CV Cylinders utilize urethane and Nitrile seals which are compatible with standard paraffin-based lubrication oils used for pneumatic cylinders. For compatibility with other fluids, consult PHD.

TEMPERATURE LIMITS

Series CV Cylinders are designed for use in temperatures from -20° to 180°F [-29° to +82°C]. For temperatures outside this range, consult PHD.

STROKE TOLERANCE

Tolerance on the nominal stroke dimension is related to the bore size and stroke length as shown in the following table:

BORE mm	NOMINAL STROKE (L)		NOMINAL STROKE TOLERANCE	
	in	mm	in	mm
20 & 25	L ≤ 4	L ≤ 100	+0.059/-0	+1.5/-0
	L > 4	L > 100	+0.079/-0	+2/-0
32, 40, & 50	L ≤ 20	L ≤ 500	+ 0.079/-0	+ 2/-0
	L > 20	L > 500	+ 0.126/-0	+ 3.2/-0
63, 80, & 100	L ≤ 20	L ≤ 500	+ 0.098/-0	+ 2.5/-0
	L > 20	L > 500	+ 0.157/-0	+ 4/-0

LUBRICATION

All units are prelubricated at the factory for service under normal operating conditions. Cylinders can be used with non-lubricated air; however, use with lubricated air will extend life.

CYLINDER WEIGHT TABLE

BORE mm	BASE WEIGHT		ADDER PER 1" [25 mm] STROKE	
	lb	kg	lb	kg
CVBx20	.55	.25	.10	.04
CVBx25	.69	.31	.12	.05
CVCx20	.52	.24	.10	.04
CVCx25	.66	.30	.12	.05
32	1.45	.66	.17	.08
40	2.08	.94	.23	.10
50	3.28	1.49	.32	.15
63	4.87	2.21	.36	.16
80	7.78	3.53	.52	.24
100	11.03	5.00	.60	.27

LIFE EXPECTANCY

Series CVB Cylinders have been tested to 10 million trouble-free cycles. Series CVC units will have shorter life due to Nitrile piston seals in place of Urethane seals. Operation with lubricated air can extend cylinder life.

MAINTENANCE

As with most PHD products, these cylinders are field repairable. Repair kits, piston and rod assemblies, port control cartridge assemblies, and main structural components are available as needed for extended service.

ENGINEERING DATA: SERIES CV CYLINDERS

CYLINDER SPEEDS

The cylinder speed and time required for the cylinder to extend or retract are dependent upon many application conditions including supply line pressure, valve rating, line size, attached tooling, flow controls, etc. Upon actuation, the cylinder will accelerate from rest to some final speed prior to end of stroke. This is illustrated by the

graph below. Using the data in the table below, the total time to extend or retract can be approximated. Actual extend and retract times will vary, especially as the application conditions change from those stated below.

	Standard & Cushion Unit	Port Control Unit (full open)
Approximate Extend or Retract Time (seconds)	$A + \left[\frac{\text{Stroke} - B}{1000 \times C} \right]$	$D + \left[\frac{\text{Stroke} - E}{1000 \times F} \right]$
EXAMPLE 50 mm bore cylinder with 200 mm stroke	$.053 + \left[\frac{200 - 48}{1000 \times 2.03} \right] = 0.13 \text{ sec}$	$.159 + \left[\frac{200 - 52}{1000 \times 0.53} \right] = 0.44 \text{ sec}$

Equation not applicable for imperial values.

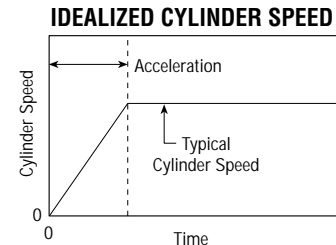

STANDARD & CUSHION UNITS

PORT CONTROL UNITS (FULL OPEN)

BORE mm	STANDARD & CUSHION UNITS					PORT CONTROL UNITS (FULL OPEN)				
	[A]	[B]		[C]		[D]	[E]		[F]	
	ACCELERATION TIME s	STROKE DURING ACCELERATION in	mm	TYPICAL CYLINDER SPEED in sec	m/sec	ACCELERATION TIME s	STROKE DURING ACCELERATION in	mm	TYPICAL CYLINDER SPEED in/sec	m/sec
20	0.025	2.3	58	200	5.08	0.065	1.2	31	35	0.89
25	0.023	1.8	46	150	3.81	0.103	1.5	38	24	0.61
32	0.027	1.3	33	105	2.67	0.120	2.1	52	33	0.84
40	0.033	1.3	33	80	2.03	0.109	2.4	61	36	0.91
50	0.053	1.9	48	80	2.03	0.159	2.1	52	21	0.53
63	0.056	1.2	30	35	0.89	0.116	2.3	58	25	0.64
80	0.079	1.2	30	25	0.64	0.143	2.0	51	18	0.46
100	0.075	1.4	36	25	0.64	0.143	2.2	56	20	0.51

NOTES: The above speed data is based on:

- 1) No attached load with a line pressure of 80 psi [5.5 bar] with a valve rated at $C_v=9.0$.
- 2) 20 mm and 25 mm cylinders tested with 0.17" ID tubing.
- 3) 32 mm and 40 mm cylinders tested with 0.28" ID tubing.
- 4) 50 mm, 63 mm, and 80 mm cylinders tested with 0.38" ID tubing.
- 5) 100 mm cylinders tested with two 0.38" ID tubes to each port from the valve.

METRIC TO IMPERIAL CONVERSION

	MULTIPLY	BY	TO OBTAIN
LENGTH	mm	.0394	in
SPEED	m/sec	39.37	in/sec

ENGINEERING DATA: SERIES CV CYLINDERS

	IMPERIAL TO METRIC CONVERSION			METRIC TO IMPERIAL CONVERSION		
	MULTIPLY	BY	TO OBTAIN	MULTIPLY	BY	TO OBTAIN
LENGTH	in	25.4	mm	mm	0.0394	in
FORCE	lbs	4.45	N	N	0.225	lbs
PRESSURE	psi	0.069	bar	bar	14.5	psi

HOW TO DETERMINE CORRECT CYLINDER SIZE

Step 1. Determine stroke and force required for the application.

Step 2. Determine the force produced by the cylinder using the graphs on page 1D-12. The cylinder force graphs are based on the following formulas and the data from the cylinder force table.

$$\begin{array}{ll} \text{IMPERIAL} & \text{METRIC} \\ F = P \times A & F = 0.1 \times P \times A \end{array}$$

F = Cylinder Force
P = Operating Pressure
A = Effective Area
(Push or Pull)

lbs
psi
in²

N
bar
mm²

CYLINDER FORCE TABLE

BORE DIA		ROD DIA		ROD DIRECTION	EFFECTIVE AREA	
in	mm	in	mm		in ²	mm ²
0.787	20	0.315	8	PUSH	0.49	314
				PULL	0.41	264
0.984	25	0.394	10	PUSH	0.76	491
				PULL	0.64	412
1.260	32	0.472	12	PUSH	1.25	804
				PULL	1.07	691
1.575	40	0.630	16	PUSH	1.95	1257
				PULL	1.64	1056
1.969	50	0.787	20	PUSH	3.04	1963
				PULL	2.56	1649
2.480	63	0.787	20	PUSH	4.83	3117
				PULL	4.34	2803
3.150	80	0.984	25	PUSH	7.79	5027
				PULL	7.03	4536
3.937	100	0.984	25	PUSH	12.17	7854
				PULL	11.41	7363

NOTE: Use pull forces for calculating double rod end performance.







Step 3. For the selected cylinder, verify that there is sufficient rod column strength based on the cylinder **extend** force and stroke length. Rod column strength curves are based on the following formula:

$$F_c = \frac{\pi^2 EI}{(LK)^2 S_f}$$

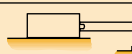
F_c = Maximum Column Force
E = Modulus of Elasticity
L = Stroke Length
I = Moment of Inertia
= π (Rod Diameter)⁴/64
K = Stroke Factor
S_f = Safety Factor

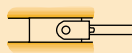
IMPERIAL
lbs
30 x 10⁶ psi
in
in⁴
(see chart)
5

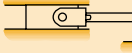
METRIC
N
207 GPa
mm
mm⁴
(see chart)
5

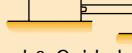
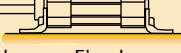
ROD END CONDITION	CYLINDER MOUNT	COLUMN STRENGTH CURVE	STROKE FACTOR K
 Fixed & Supported	 Fixed	A	2
 Pivoted & Guided	 Pivot at Rear	A	2
 Pivoted & Guided	 Fixed	See Note	0.7
 Fixed & Guided	 Fixed	See Note	0.5

NOTE: In these two cases, column strength is sufficient for stroke lengths less than or equal to 40 in [1000 mm] for CVA units and 30 in [750 mm] for CVB and CVC units.

Example:

Step 1. For a specific application, it has been determined that a cylinder is required to operate within the following parameters:

P = Operating Pressure = 80 psi [5.5 bar]
F = Required Extend Force = 150 lbs [667 N]
L = Required Stroke = 30 in [762 mm]
V = Required Maximum Velocity = 20 in/sec [.51 m/sec]
M = Attached Load = 75 lbs [35 kg]

Mounting type: Rod end is pivoted and guided
Cylinder is pivoted at rear

Step 2. Using the Cylinder Force Charts on page 1D-12, locate 80 psi [5.5 bar] on the horizontal axis. Follow the line vertically until it intersects the **solid** (extend) diagonal line on the chart. The 32 mm cylinder extend force is only 100 lbs [445 N] at 80 psi [5.5 bar] less than the required 150 lbs [667 N]. The 40 mm is capable of just over 150 lbs [667 N] extend force at this pressure. Select the 40 mm and proceed to the next step.

Step 3. Check column strength. Based on the mounting types, use curve A on the 40 mm Rod Column Strength Chart (see page 1D-12). At 150 lbs [667 N] extend force, the maximum allowable cylinder stroke is 27 in [686 mm]. However, the required stroke is 30 in [762 mm]. Assuming the stroke cannot be changed, it is necessary to select a cylinder with a larger rod diameter. Checking the 50 mm cylinder in the same way as was done for the 40 mm shows that the 50 mm cylinder is acceptable.

Step 4. Using the Kinetic Energy charts on page 1D-11, find the point on the 50 mm chart that corresponds to the given maximum velocity and attached load. The chart shows that the cylinder must be specified with cushions to properly decelerate the load.

ENGINEERING DATA: SERIES CV CYLINDERS

MAXIMUM ALLOWABLE KINETIC ENERGY GRAPHS

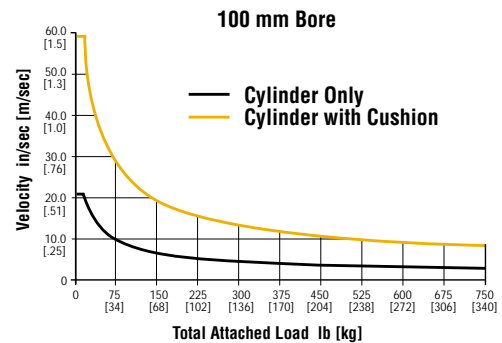
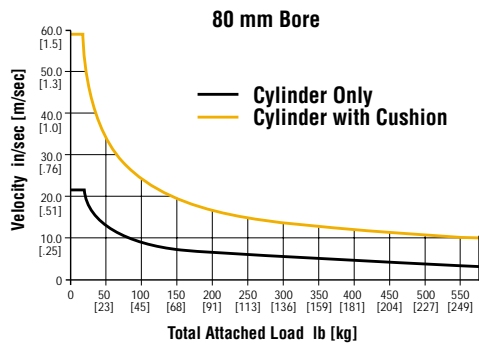
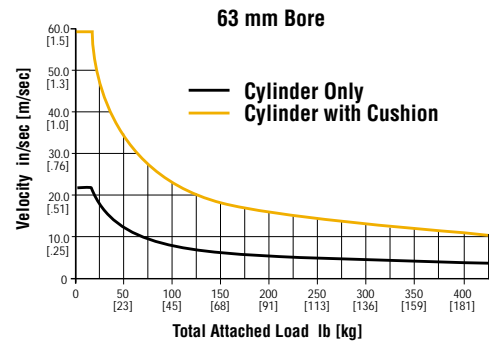
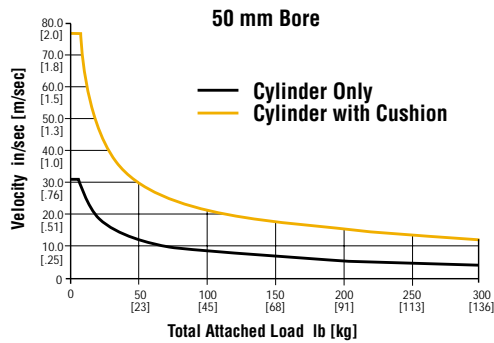
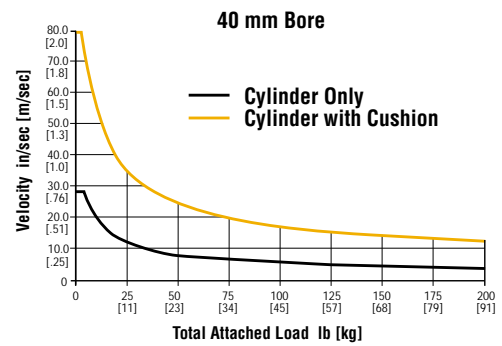
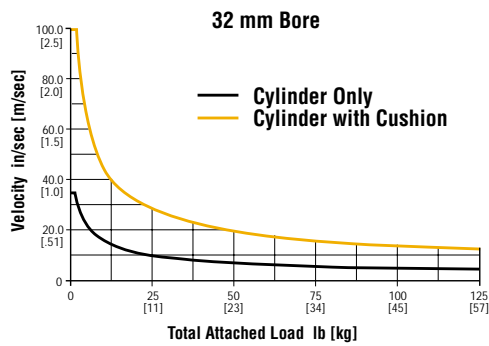
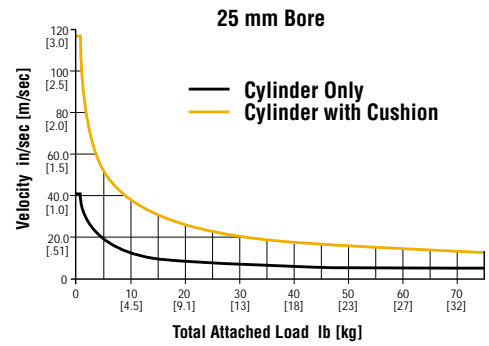
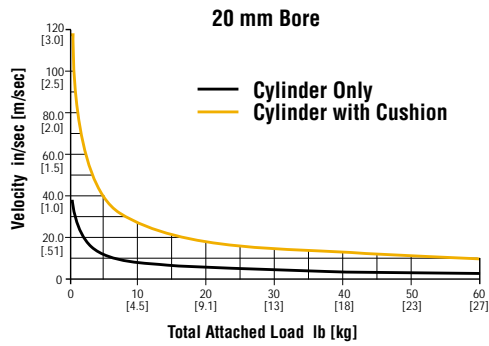

1D

ENGINEERING DATA: SERIES CV CYLINDERS

CYLINDER FORCE CHARTS

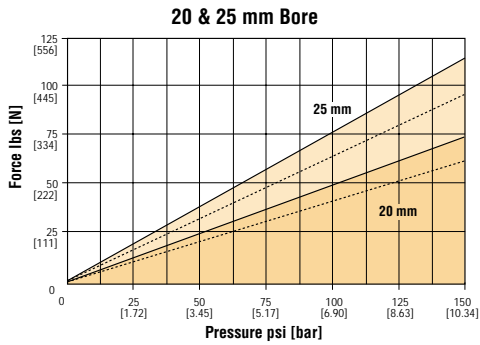

ROD COLUMN STRENGTH CHARTS

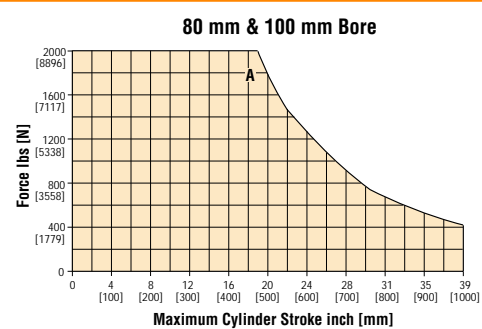
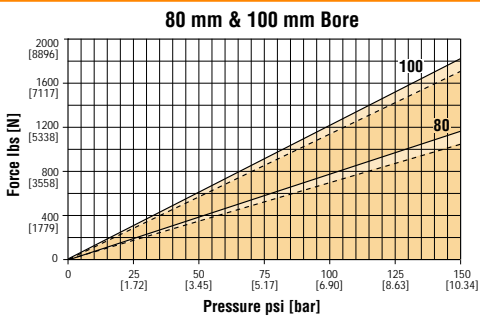
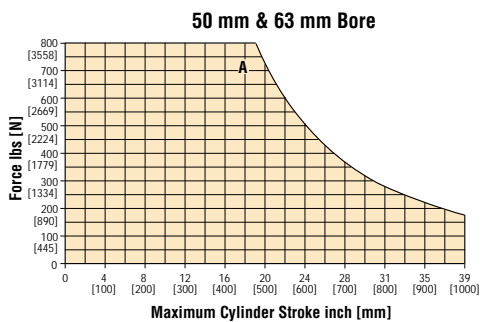
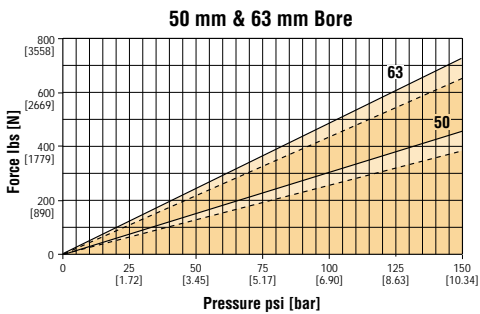
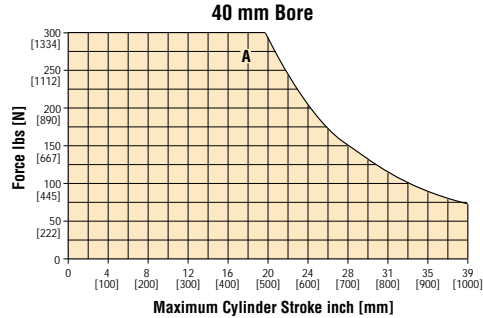
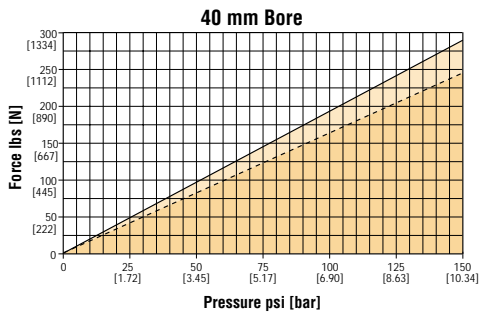
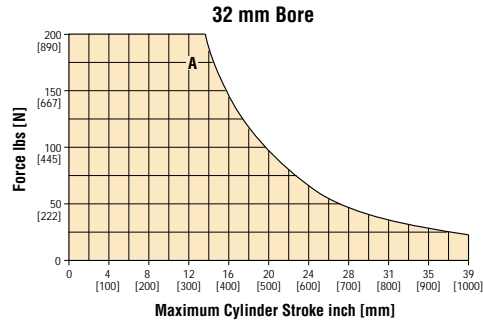
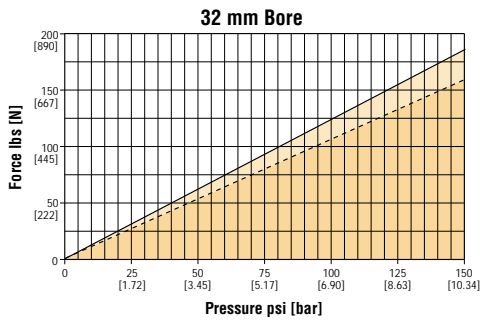
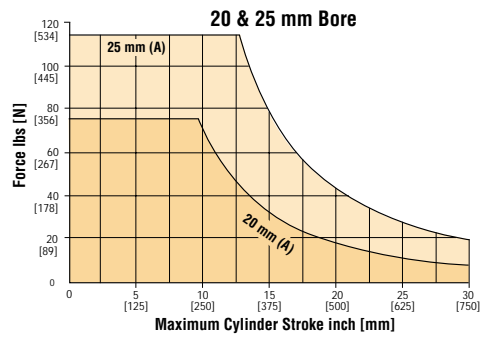

1D

OPTIONS: SERIES CV CYLINDERS

DB CUSHION CONTROL IN BOTH DIRECTIONS
(standard location 1 & 5, see note)

DE CUSHION CONTROL ON EXTEND ONLY
(standard location 1, not available on 3 position units)

DR CUSHION CONTROL ON RETRACT ONLY
(standard location 5, not available on 3 position units)

CUSHION CONTROL OPTIONS

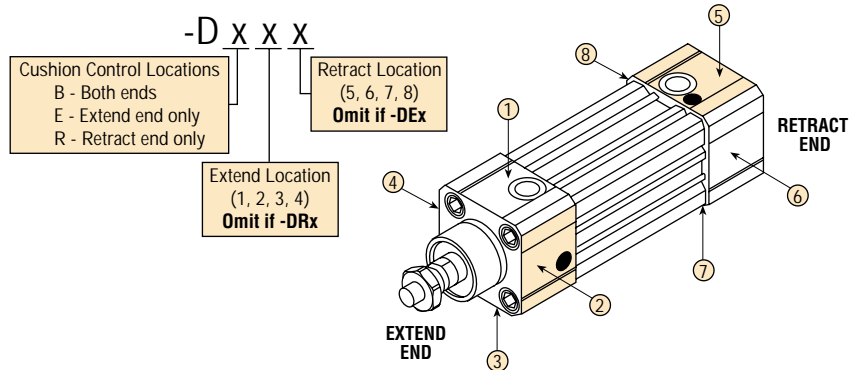

PHD cushions are designed for smooth deceleration at the end of stroke. When the cushion is activated, the remaining volume in the cylinder must exhaust past an adjustable needle which controls the amount of deceleration. The effective cushion lengths for each bore size are shown in the table below. To specify different cushion control locations on the head or cap, see option code above.

Note: Cushion controls on 3 position units are available in locations 1 and 5 only and as -DB only. 3 position units will have cushion on full extend and full retract only.

Unit shown is -DB25, cushion in location 2 on extend end and cushion in location 5 on retract end. (Ports are shown in standard locations 1 & 5.) Cushion control locations on 3 position units are 1 and 5 only and will receive a control on the head and intermediate head only.

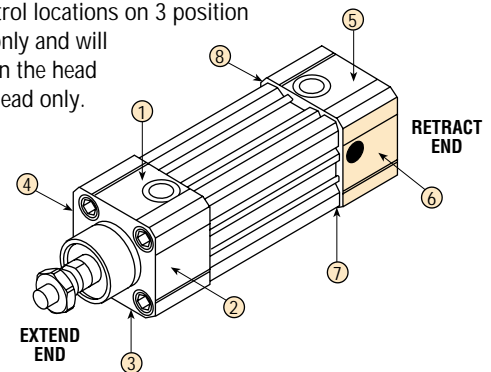

Unit shown is -DR6, cushion in location 6 on retract end and none on extend end. (Ports are shown in standard locations 1 & 5.)

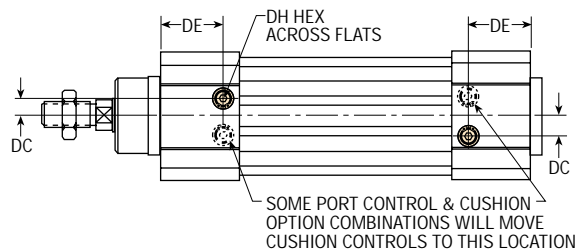

LETTER DIM	BORE SIZE															
	20 mm		25 mm		32 mm		40 mm		50 mm		63 mm		80 mm		100 mm	
	in	mm	in	mm	in	mm	in	mm	in	mm	in	mm	in	mm	in	mm
DC	.189	4.8	.205	5.2	.276	7.0	.374	9.5	.354	9.0	.354	9.0	.591	15.0	.630	16.0
DE	.583	14.8	.559	14.2	.965	24.5	1.083	27.5	1.043	26.5	1.201	30.5	1.181	30.0	1.339	34.0
DH	—	2.5	—	2.5	—	2.5	—	2.5	—	2.5	—	2.5	—	3.0	—	3.0
EFFECTIVE CUSHION LENGTH	.441	11.2	.469	11.9	.598	15.2	.807	20.5	.870	22.1	.803	20.4	.894	22.7	1.189	30.2

F22 4 WRENCH FLATS ON ROD END ⊕

With this option, the rod is supplied with four rod end flats instead of the standard two flats. If this option is specified on double rod units, both rod ends will be supplied with four wrench flats.

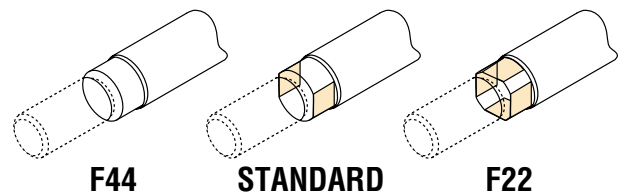

F44 NO WRENCH FLATS ON ROD END ⊕

This option omits rod end wrench flats. If this option is specified on double rod units, both rod ends will be supplied without wrench flats.

⊕ This option does not dimensionally comply with the ISO 6431/VDMA 24562 or ISO 6432 specifications.

All dimensions are reference only unless specifically toleranced.

OPTIONS: SERIES CV CYLINDERS

H46 **RODLOK® READY CYLINDER**
Available on single rod units only.
(Rodlok sold separately) ⊕

H47 **RODLOK® CYLINDER & RODLOK®** Available on single rod units only.
(preassembled) ⊕

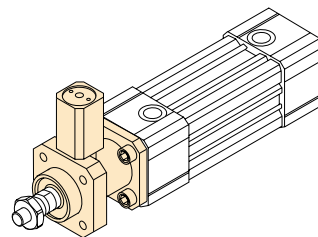

PHD's Rodlok® is designed to lock the piston rod while in a stationary position. When pressure is removed from the port of the Rodlok, the mechanism grips the rod and prevents it from moving. Loads are held indefinitely without any power. The Rodlok is **not** designed for dynamic use as a piston rod deceleration device. Standard ISO 6431/VDMA 24562 or ISO 6432 mountings can still be attached to the Rodlok adaptor.

Option H46 provides a Rodlok ready cylinder with appropriate rod extension and materials for use with PHD's Rodlok.

Option H47 provides a cylinder and Rodlok pre-assembled. The port for the Rodlok will be assembled in the same position as the port on the extend end of the cylinder.

The Rodlok locking device and adaptor can be purchased separately as kits. See chart at right. The locking device and adaptor are not available with the -Z1 corrosion resistant finish.

Dimensions continued on next page.

BORE mm	STATIC LOCKING FORCE	
	lb	N
20	79	350
25	90	400
32	135	600
40	225	1000
50	337	1500
63	495	2200
80	674	3000
100	1124	5000

NOTE: Locking force given in table is the actual locking force and does not include any safety factor.

OPERATING PRESSURE

The operating pressure for the locking device is different than the operating pressure for the cylinder with the Rodlok attached. The locking device of the Rodlok is designed with an operating pressure range of 60 psi minimum to 150 psi maximum [4 to 10 bar]. The Series CV Cylinder with a Rodlok attached has an operating pressure range of 22 psi minimum to 150 psi maximum [1.5 to 10 bar].

⊕ This option does not dimensionally comply with the ISO 6431/VDMA 24562 or ISO 6432 specifications.

RODLOK® KITS

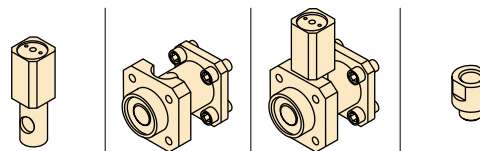

BORE mm	LOCKING DEVICE KIT	ADAPTOR KIT*	COMPLETE RODLOK®*	IMPERIAL PORT ADAPTOR
20	63459-07-1	63460-07-1	63461-07-1	—
25	63459-08-1	63460-08-1	63461-08-1	—
32	63459-01-1	63460-01-1	63461-01-1	—
40	63459-02-1	63460-02-1	63461-02-1	63465-1
50	63459-03-1	63460-03-1	63461-03-1	63465-1
63	63459-04-1	63460-04-1	63461-04-1	63465-1
80	63459-05-1	63460-05-1	63461-05-1	63465-1
100	63459-06-1	63460-06-1	63461-06-1	63465-1

NOTES:

- 1) *Kits ship with cylinder mounting hardware.
- 2) Rodlok is intended for use only on -H46 cylinder.
- 3) Imperial port adaptor converts port from G1/8 to 1/8" NPT for use with -L9 cylinders

Plumbing Schematic

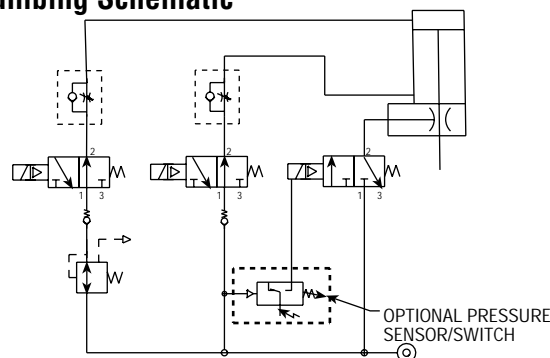

The pneumatic schematic above shows typical valving for cylinder and Rodlok for both horizontal and vertical operation. The schematic shows three 3/2 way valves, one for each port on the cylinder and one for the Rodlok port. The use of two valves on the cylinder allows for both ports to be pressurized when valves are de-energized. The use of an in-line regulator allows the cylinder ports to be pressurized at different pressures. This allows the cylinder to balance out the opposing pressure and force of the attached load. Once piston rod motion has stopped, the Rodlok can be engaged by de-energizing its valve and releasing its pressure. The use of check valves and built in PHD Port Controls® is recommended. Pressure switch shown is optional and application specific.

OPTIONS: SERIES CV CYLINDERS

RODLOK® DIMENSIONS

(continued from previous page)

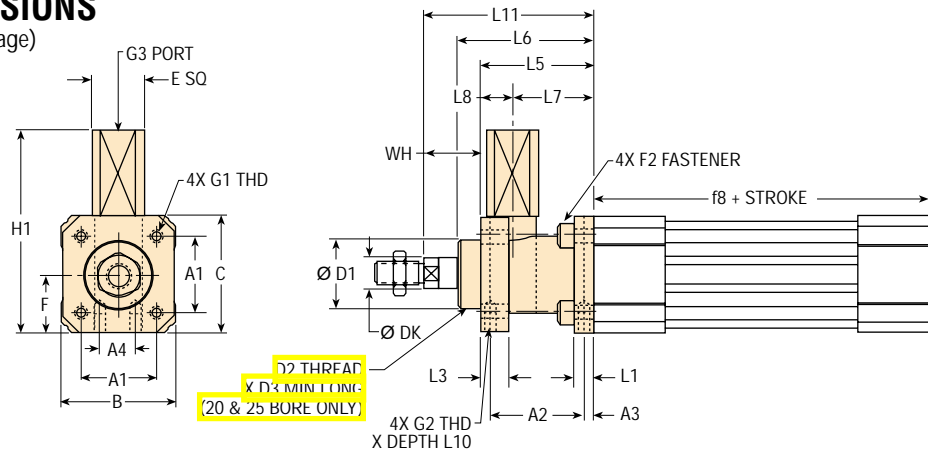

LETTER DIM	BORE SIZE															
	20 mm		25 mm		32 mm		40 mm		50 mm		63 mm		80 mm		100 mm	
	in	mm	in	mm	in	mm	in	mm	in	mm	in	mm	in	mm	in	mm
A1	1.024	26.0	1.063	27.0	1.280	32.5	1.496	38.0	1.831	46.5	2.224	56.5	2.835	72.0	3.504	89.0
A2	—	—	—	—	1.575	40.0	1.811	46.0	2.126	54.0	2.165	55.0	2.756	70.0	2.756	70.0
A3	—	—	—	—	.165	4.2	.177	4.5	.453	11.5	.295	7.5	.394	10.0	.394	10.0
A4	—	—	—	—	.630	16.0	.827	21.0	.945	24.0	1.260	32.0	1.732	44.0	2.362	60.0
B	1.457	37.0	1.575	40.0	1.890	48.0	2.205	56.0	2.677	68.0	3.228	82.0	3.937	100.0	4.724	120.0
C	1.457	37.0	1.575	40.0	1.969	50.0	2.283	58.0	2.756	70.0	3.346	85.0	4.134	105.0	5.118	130.0
D1	.866	22.0	.866	22.0	1.181	30.0	1.378	35.0	1.575	40.0	1.772	45.0	1.772	45.0	2.165	55.0
D2	M22 x 1.5		M22 x 1.5		—	—	—	—	—	—	—	—	—	—	—	—
D3	.590	15.0	.669	17.0	—	—	—	—	—	—	—	—	—	—	—	—
DK	.315	8.0	.394	10.0	.472	12.0	.630	16.0	.787	20.0	.787	20.0	.984	25.0	.984	25.0
E	.787	20.0	.787	20.0	.866	22.0	1.024	26.0	1.260	32.0	1.535	39.0	1.732	44.0	1.929	49.0
F	.728	18.5	.787	20.0	.984	25.0	1.142	29.0	1.378	35.0	1.673	42.5	2.067	52.5	2.559	65.0
F2	M4 x 0.7 x 20		M4 x 0.7 x 20		M6 x 1 x 20		M6 x 1 x 20		M8 x 1.25 x 30		M8 x 1.25 x 30		M10 x 1.5 x 30		M10 x 1.5 x 30	
G1	M4 x 0.7		M4 x 0.7		M6 x 1		M6 x 1		M8 x 1.25		M8 x 1.25		M10 x 1.5		M10 x 1.5	
G2	—		—		M5		M5		M6		M8		M8		M8	
G3	M5		M5		M5		G 1/8		G 1/8		G 1/8		G 1/8		G 1/8	
H1	2.795	71.0	2.854	72.5	3.346	85.0	3.839	97.5	4.626	117.5	5.256	133.5	6.752	171.5	7.441	189.0
L1	.354	9.0	.315	8.0	.315	8.0	.394	10.0	.591	15.0	.591	15.0	.630	16.0	.630	16.0
L3	.354	9.0	.315	8.0	.472	12.0	.472	12.0	.630	16.0	.591	15.0	.630	16.0	.709	18.0
L5	1.575	40.0	1.732	44.0	1.890	48.0	2.165	55.0	2.756	70.0	2.756	70.0	3.543	90.0	3.622	92.0
L6	2.244	57.0	2.480	63.0	2.283	58.0	2.559	65.0	3.228	82.0	3.228	82.0	4.331	110.0	4.528	115.0
L7	1.142	29.0	1.220	31.0	1.260	32.0	1.398	35.5	1.929	49.0	1.929	49.0	2.441	62.0	2.559	65.0
L8	.433	11.0	.512	13.0	.630	16.0	.768	19.5	.827	21.0	.827	21.0	1.102	28.0	1.063	27.0
L10	—	—	—	—	.315	8.0	.394	10.0	.472	12.0	.472	12.0	.630	16.0	.630	16.0
L11	2.520	64.0	2.835	72.0	2.913	74.0	3.346	85.0	4.213	107.0	4.213	107.0	5.354	136.0	5.630	143.0
WH	.945	24.0	1.102	28.0	1.024	26.0	1.181	30.0	1.457	37.0	1.457	37.0	1.811	46.0	2.008	51.0

NOTES:

- 1) -H47 units have Rodlok® port aligned with cylinder port on extend.
- 2) See page 1D-6 for complete cylinder dimensions.



L9 NPT PORTS

This option provides NPT ports instead of the standard BSPP ports. The NPT ports are located in the same location as the BSPP ports.

⊕ This option does not dimensionally comply with the ISO 6431/VDMA 24562 or ISO 6432 specifications.

BORE [mm]	OPTIONAL NPT PORT	STANDARD BSPP PORT
20	1/8*	G 1/8*
25	1/8*	G 1/8*
32	1/8	G 1/8
40	1/4	G 1/4
50	1/4	G 1/4
63	3/8	G 3/8
80	3/8	G 3/8
100	1/2	G 1/2

*When port controls are specified on the same face as ports, the standard metric port is M5 and the -L9 option provides a 10-32 port.

All dimensions are reference only unless specifically tolerated.

OPTIONS: SERIES CV CYLINDERS

K EXTRA ROD EXTENSION ⊕

Extra rod extension can be achieved by specifying the option -K followed by the length code. Rod extension is available in 5 mm increments. If this option is specified on double rod units, both rod ends will be supplied with the same extra rod extension. Contact PHD for other combinations.

Length code examples
K5 = 5 mm of extra rod extension
K15 = 15 mm, etc.

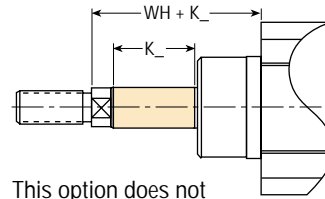

⊕ This option does not dimensionally comply with the ISO 6431/VDMA 24562 or ISO 6432 specifications.

BORE [mm]	WH	
	in	mm
20	0.945	24.0
25	1.102	28.0
32	1.024	26.0
40	1.181	30.0
50	1.457	37.0
63	1.457	37.0
80	1.811	46.0
100	2.008	51.0

Z1 CORROSION RESISTANT

By specifying this option, a stainless steel rod with hard chrome plating is supplied in place of the standard hard chrome plated steel material. Appropriate coating is supplied on ferrous parts.

M MAGNET FOR PHD MINIATURE REED AND MAGNETORESISTIVE SWITCHES

This option equips the cylinder with a magnetic band on the piston for use with PHD Miniature Reed and Magnetoresistive Switches listed below. These switches mount easily to the cylinder using "T" slots in the body. See Switches and Sensors section in PHD's main catalog for complete switch information. Three position units will receive a magnet on both cylinder 1 and cylinder 2 when specified with -M option.

SERIES 6250 MAGNETORESISTIVE SWITCHES

PART NO.	DESCRIPTION	COLOR
62505-1-02	NPN (Sink) DC Magnetoresistive, 2 m cable	Brown
62506-1-02	PNP (Source) DC Magnetoresistive, 2 m cable	Tan
62515-1	NPN (Sink) DC Magnetoresistive, Quick Connect	Brown
62516-1	PNP (Source) DC Magnetoresistive, Quick Connect	Tan

SERIES 6250 REED SWITCHES

PART NO.	DESCRIPTION	COLOR
62507-1-02	AC/DC Reed, 2 m cable	Silver
62517-1	AC/DC Reed, Quick Connect	Silver

Connector Detail

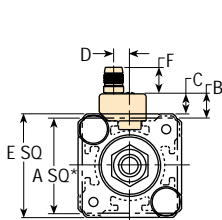
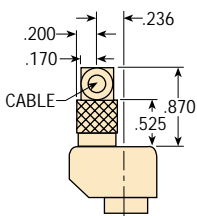

20 & 25 mm units

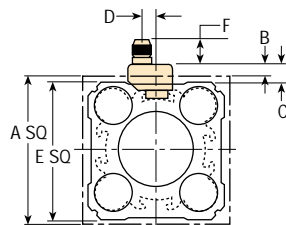

32, 40, & 50 mm units

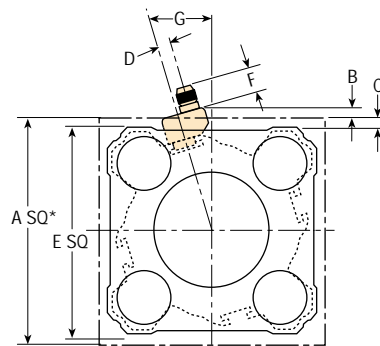

63, 80, & 100 mm units

Connector Detail

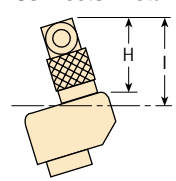

LETTER DIM	BORE SIZE															
	20 mm		25 mm		32 mm		40 mm		50 mm		63 mm		80 mm		100 mm	
	in	mm	in	mm	in	mm	in	mm	in	mm	in	mm	in	mm	in	mm
A*	1.339	34.0	1.339	34.0	1.969	50.0	2.283	58.0	2.756	70.0	3.346	85.0	4.134	105.0	5.118	130.0
B	.343	8.7	.441	11.2	.276	7.0	.197	5.0	.236	6.0	.236	6.0	.157	4.0	.020	0.5
C	.283	7.2	.323	8.2	.295	7.5	.256	6.5	.276	7.0	.335	8.5	.295	7.5	.315	8.0
D	.236	6.0	.236	6.0	.236	6.0	.236	6.0	.236	6.0	.236	6.0	.236	6.0	.236	6.0
E	1.457	37.0	1.575	40.0	1.949	49.5	2.205	56.0	2.697	68.5	3.150	80.0	3.858	98.0	4.528	115.0
F	.374	9.5	.374	9.5	.374	9.5	.374	9.5	.374	9.5	.374	9.5	.374	9.5	.374	9.5
G	—	—	—	—	—	—	—	—	—	—	17°	17°	20°	20°	24°	24°
H	.870	22.1	.870	22.1	.870	22.1	.870	22.1	.870	22.1	.831	21.1	.819	20.8	.795	20.2
I	1.213	30.8	1.311	33.3	1.146	29.1	1.087	27.6	1.106	28.1	1.059	26.9	.965	24.5	.811	20.6

NOTE: *ISO/VDMA max square size

OPTIONS: SERIES CV CYLINDERS

PB **PORT CONTROLS® ON BOTH ENDS**
(standard location 1 & 5, see note) ⊕

PE **PORT CONTROLS® ON EXTEND ONLY** (standard location 1, not available on 3 position units) ⊕

PR **PORT CONTROLS® ON RETRACT ONLY** (standard location 5, not available on 3 position units) ⊕

PHD's Port Control® is a built-in flow control for regulating the speed of the cylinder through its entire stroke. The Port Control operates on the "meter-out" principle and features an adjustable needle in a cartridge with a check seal. The self-locking needle has micrometer threads and is adjustable under pressure. The needle determines the orifice size which controls the exhaust flow rate of the actuator. The check seal expands while air is exhausting from the actuator, forcing the air to exhaust past the adjustable needle. The check seal collapses to allow a free flow of incoming air. The PHD Port Control saves space and eliminates the cost of fittings and installation for external flow control valves. See engineering data for cylinder speeds with PHD's Port Controls. Refer to option code below to specify port control locations. Three position port control locations are 1 and 5 only and will receive a control on the head, intermediate head, and cap.

PORT CONTROL OPTIONS

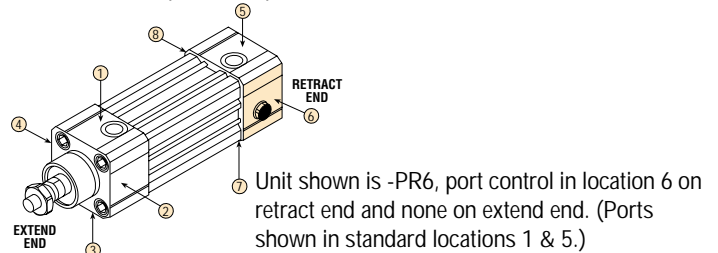
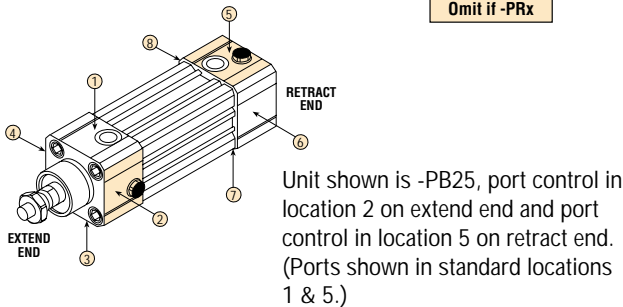
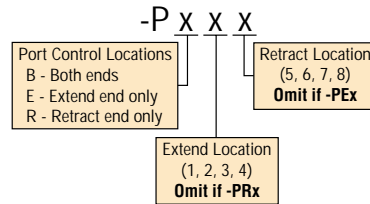

NOTES: Port controls are not available on same end which has -UB0x or -UBx0 (four ports) specified. Three position units are available only with -PB and only in locations 1 and 5.

⊕ For 32, 40, 50, and 63 mm, the port control extends beyond VDMA specified square size. See dimension BP.

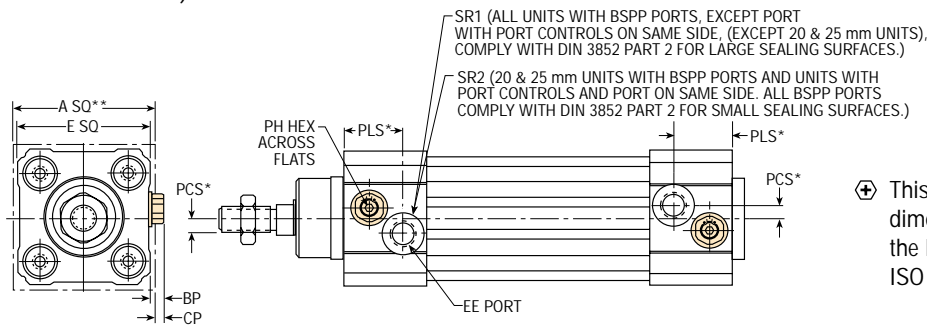

⊕ This option does not dimensionally comply with the ISO 6431/VDMA 24562 or ISO 6432 specifications.

LETTER	BORE SIZE															
	20 mm		25 mm		32 mm		40 mm		50 mm		63 mm		80 mm		100 mm	
	in	mm	in	mm	in	mm	in	mm	in	mm	in	mm	in	mm	in	mm
A**	1.339	34.0	1.339	34.0	1.969	50.0	2.283	58.0	2.756	70.0	3.346	85.0	4.134	105.0	5.118	130.0
BP	.125	3.2	.153	3.9	.177	4.5	.240	6.1	.110	2.8	.201	5.1	.134	3.4	.205	5.2
CP	.184	4.7	.271	6.9	.169	4.3	.201	5.1	.083	2.1	.102	2.6	-.004	-0.1	-.091	-2.3
E	1.457	37.0	1.575	40.0	1.949	49.5	2.205	56.0	2.697	68.5	3.150	80.0	3.858	98.0	4.528	115.0
EE	10-32 [†]	M5 [†]	10-32 [†]	M5 [†]	G1/8		G1/4		G1/4		G3/8		G3/8		G1/2	
PCS*	.276	7.0	.276	7.0	.197	5.0	.236	6.0	.236	6.0	.449	11.4	.512	13.0	.906	23.0
PH	—	2.5	—	2.5	—	2.5	—	2.5	—	2.5	—	3.0	—	3.0	—	6.0
PLS*	.571	14.5	.571	14.5	.866	22.0	.925	23.5	.906	23.0	.984	25.0	1.024	26.0	1.142	29.0
SR1	—	—	—	—	.748	19.0	.984	25.0	.984	25.0	1.102	28.0	1.102	28.0	1.339	34.0
SR2	.319	8.1	.319	8.1	.657	16.7	.827	21.0	.945	24.0	.945	24.0	1.063	27.0	1.299	33.0

NOTES:

- 1) *Dimensions shown are for units with port and port control in the same location. For units with other port and port control combinations, standard port location dimensions apply. Ports may be located on either side of the cylinder centerline depending on port control and cushion option combinations.
- 2) **VDMA max square size
- 3) [†]Port shown is for when port control is specified in the same location as the port. For all other port control locations the port is the standard G1/8.

All dimensions are reference only unless specifically toleranced.

OPTIONS: SERIES CV CYLINDERS

1D

UB ALTERNATE PORT LOCATION (not available on 3 position units)

With this option, alternate port locations can be specified, providing increased flexibility and customer convenience. See option code below to specify port locations. Three position units available with ports in standard locations 1 and 5 only.

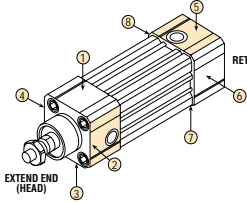

Unit shown is -UB25, port in location 2 on extend end and port in location 5 on retract end.

PORT LOCATION OPTIONS

-UB x x

- Extend Location (Head)
(0, 1, 2, 3, 4)
0 = All four sides
- Retract Location (Cap)
(0, 5, 6, 7, 8)
0 = All four sides

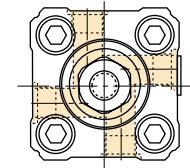

PORTS ON ALL 4 SIDES (0 IN PORT OPTION CODE) NOT AVAILABLE WITH PHD PORT CONTROLS ON SAME END

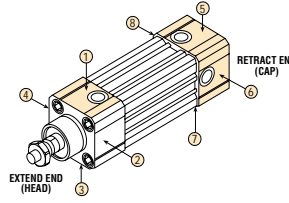

Unit shown is -UB10, port in location 1 on extend end, and ports on all 4 sides on retract end. (Not available with PHD port controls on retract.)

T44 FEMALE ROD END

This option provides a female rod end in place of the standard male rod end. See catalog dimensional pages for standard rod ends. This rod end deviates from ISO 6431/VDMA 24562 or ISO 6432.

Double rod units will receive the same rod end on both rods unless otherwise specified as shown in the double rod option description.

T55 PLAIN ROD END

This option provides a plain rod end with wrench flats. Standard PHD Series CV Cylinders are supplied with a male rod end. This rod end deviates from ISO 6431/VDMA 24562 or ISO 6432.

Double rod units will receive the same rod end on both rods unless otherwise specified as shown in the double rod option description.

TEE MALE OVERSIZE ROD END

This option provides a male oversize thread rod end in place of the standard male rod end. See catalog dimensional pages for standard rod ends. Double rod units will receive the same rod end on both rods unless otherwise specified as shown in the double rod option description.

TEE MALE OVERSIZE ROD END

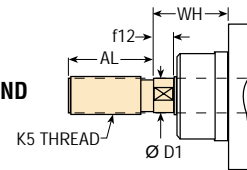

T44 FEMALE ROD END

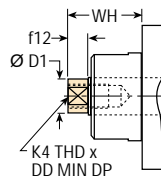

T55 PLAIN ROD END

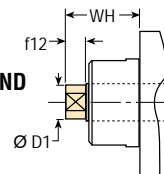

LETTER DIM	BORE SIZE															
	20 mm		25 mm		32 mm		40 mm		50 mm		63 mm		80 mm		100 mm	
	in	mm	in	mm	in	mm	in	mm	in	mm	in	mm	in	mm	in	mm
AL	—	—	—	—	.827	21.0	.906	23.0	1.220	31.0	1.220	31.0	1.535	39.0	1.535	39.0
D1	.315	8.00	.375*	9.53*	.447	11.35	.599	15.22	.757	19.23	.757	19.23	.954	24.23	.954	24.23
f12	.197	5.0	.236	6.0	.236	6.0	.256	6.5	.315	8.0	.315	8.0	.394	10.0	.394	10.0
K4	M5 x 0.8		M6 x 1.0		M8 x 1.25		M10 x 1.5		M12 x 1.75		M12 x 1.75		M16 x 2.0		M16 x 2.0	
K5	—		—		M12 x 1.25		M16 x 1.5		M20 x 1.5		M20 x 1.5		M24 x 3		M24 x 3	
DD min	.413	10.5	.492	12.5	.551	14.0	.669	17.0	.748	19.0	.748	19.0	.827	21.0	.827	21.0
WH	.945	24.0	1.102	28.0	1.024	26.0	1.181	30.0	1.457	37.0	1.457	37.0	1.811	46.0	2.008	51.0

*Dimension shown is for -T44 rod end only. -T55 option dimension is .394 in [10.0 mm].

Unit shown is -T51, plain on extend end and male thread per VDMA 24562 on retract end.

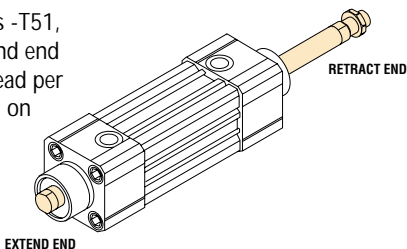

DOUBLE ROD END OPTIONS

-T x x

- Extend End
1 = Male thread VDMA 24562 (Standard)
4 = Female undersized thread
5 = Plain
- Retract End
1 = Male thread VDMA 24562 (Standard)
4 = Female undersized thread
5 = Plain

⊕ This option does not dimensionally comply with the ISO 6431/VDMA 24562 or ISO 6432 specifications.

MOUNTING STYLES: SERIES CV CYLINDERS

P&Q PIVOT MOUNT ON SIZES 20 & 25 ONLY

This style specifies a pivot mount cap. This style conforms to ISO 6432 customer interface and overall unit length when specified with optional -P or -Q mounting. Pivot pins and base mounting brackets are available, see mounting section.

LETTER DIM/ TOLERANCE	BORE SIZE			
	20 mm		25 mm	
	in	mm	in	mm
BA	0.866	22.0	0.866	22.0
BE	M22 x 1.5		M22 x 1.5	
CD/H9	0.315	8.0	0.315	8.0
EW/d13	0.630	16.0	0.630	16.0
L MIN	0.472	12.0	0.472	12.0
XC/** (*)	3.740	95.0	4.094	104.0

NOTES:

- 1) *Dimensions shown are for CVC units . Add to XC dimension .315 in [8 mm] for CVB20 and .236 in [6 mm] for CVB25.
- 2) **±.039 in [±1 mm]

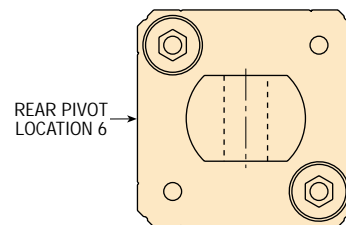
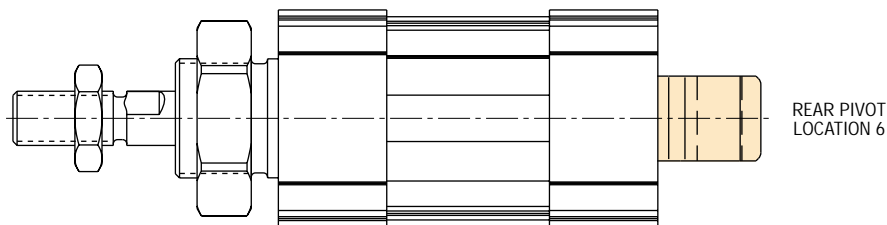
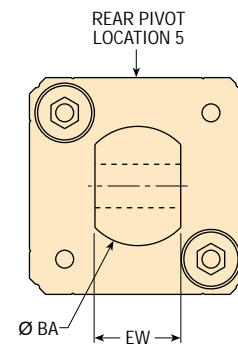
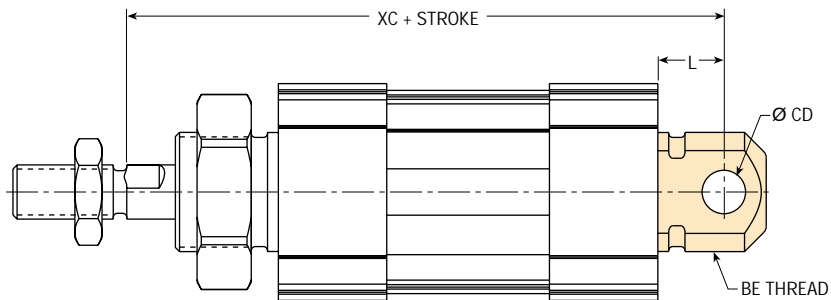

MOUNTING STYLES: SERIES CV CYLINDERS

V STANDARD MOUNTING (iso 6431/vdma 24562 & ISO 6432)

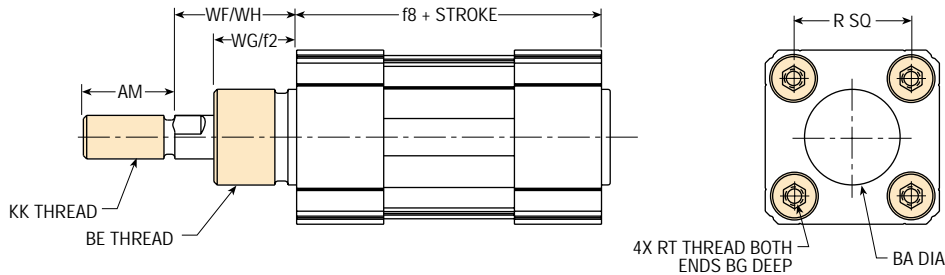

LETTER DIM/ TOLERANCE	BORE SIZE															
	20 mm		25 mm		32 mm		40 mm		50 mm		63 mm		80 mm		100 mm	
	in	mm	in	mm	in	mm	in	mm	in	mm	in	mm	in	mm	in	mm
AM	0.748	19.0	0.827	21.0	0.827	21.0	0.906	23.0	1.220	31.0	1.220	31.0	1.535	39.0	1.535	39.0
BA	0.866	22.0	0.866	22.0	1.181	30.0	1.378	35.0	1.575	40.0	1.772	45.0	1.772	45.0	2.165	55.0
BE	M22 x 1.5		M22 x 1.5		—		—		—		—		—		—	
BG min	0.472	12.0	0.472	12.0	0.709	18.0	0.709	18.0	0.787	20.0	0.787	20.0	0.787	20.0	0.787	20.0
f8	2.323*	59.0*	2.520*	64.0*	3.701	94.0	4.134	105.0	4.173	106.0	4.764	121.0	5.039	128.0	5.433	138.0
KK	M8 x 1.25		M10 x 1.25		M10 x 1.25		M12 x 1.25		M16 x 1.5		M16 x 1.5		M20 x 1.5		M20 x 1.5	
R	1.024	26.0	1.063	27.0	1.280	32.5	1.496	38.0	1.831	46.5	2.224	56.5	2.835	72.0	3.504	89.0
RT	M4 x 0.7		M4 x 0.7		M6 x 1		M6 x 1		M8 x 1.25		M8 x 1.25		M10 x 1.5		M10 x 1.5	
WF	0.945	24.0	1.102	28.0	—		—		—		—		—		—	
WH	—		—		1.024	26.0	1.181	30.0	1.457	37.0	1.457	37.0	1.811	46.0	2.008	51.0
WG	0.669	17.0	0.748	19.0	—		—		—		—		—		—	
f2	—		—		0.728	18.5	0.807	20.5	1.083	27.5	1.083	27.5	1.319	33.5	1.437	36.5

*Dimensions shown are for CVC units. Add to f8 dimension .315 [8 mm] for CVB20 and .236 in [6 mm] for CVB25.

MOUNTING ACCESSORIES: SERIES CV CYLINDERS

SELF-ALIGNING PISTON ROD COUPLERS - METRIC



New metric rod couplers are an ideal accessory for use with Series CV ISO/VDMA cylinders.

To order, specify the model number.

MODEL NO.	LETTER DIMENSION						
	A	B min	C min	D min	E	F	G
M6	M6 x 1.0	1.00 [25.4]	0.625 [15.9]	1.875 [47.6]	0.500 [12.7]	0.875 [22.2]	0.197 [5.0]
M8	M8 x 1.25	1.00 [25.4]	0.625 [15.9]	1.875 [47.6]	0.500 [12.7]	0.875 [22.2]	0.197 [5.0]
M10	M10 x 1.25	1.00 [25.4]	.625 [15.9]	1.875 [47.6]	.50 [12.7]	.875 [22.2]	.197 [5.0]
M12	M12 x 1.25	1.13 [28.6]	.750 [19.0]	2.187 [55.5]	.50 [12.7]	1.0 [25.4]	.236 [6.0]
M16	M16 x 1.5	1.75 [44.5]	1.125 [28.5]	3.312 [84.1]	.812 [20.6]	1.562 [39.7]	.314 [8.0]
M20	M20 x 1.5	1.75 [44.5]	1.125 [28.5]	3.312 [84.1]	.812 [20.6]	1.562 [39.7]	.394 [10.0]

NOTE: NUMBERS IN [] ARE mm. IMPERIAL EQUIVALENTS ARE PROVIDED FOR CONVENIENCE.

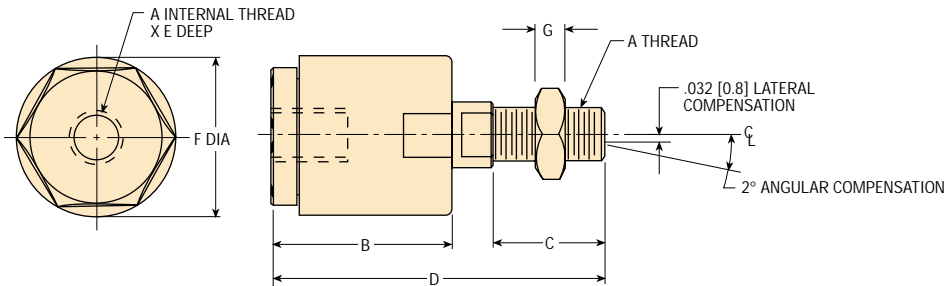

BENEFITS

- Rod Couplers eliminate expensive precision machining for mounting fixed or rigid cylinder on guide or slide applications.
- Cylinder efficiency is increased by eliminating friction caused by misalignment. Couplers compensate for 2° angular error and 1/32" [0.8 mm] lateral misalignment on push and pull stroke.
- Couplers provide greater reliability and reduce cylinder and component wear, simplifying alignment problems in the field.
- Rod Couplers are manufactured from high tensile and hardened steel components.

MOUNTING ACCESSORIES: SERIES CV CYLINDERS

RECTANGULAR FLANGE MOUNTING SIZES 20 & 25 mm (MF8 PER ISO 6432)

1D

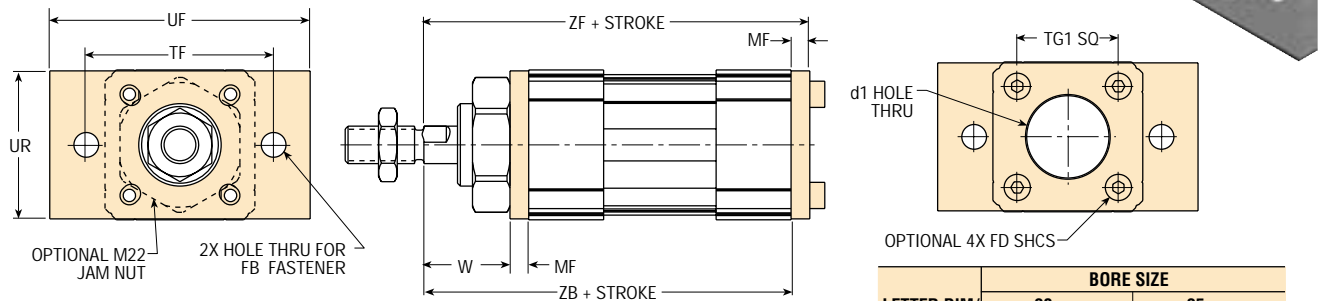

LETTER DIM/ TOLERANCE	BORE SIZE			
	20 mm		25 mm	
	in	mm	in	mm
d1/H11	0.866	22.0	0.866	22.0
FB/H13	M6 x 1.0		M6 x 1.0	
FD	M4 x 0.7 x 18		M4 x 0.7 x 18	
TG1	1.024	26.0	1.063	27.0
MF	0.197	5.0	0.197	5.0
TF/Js14	1.969	50.0	1.969	50.0
UF max	2.756	70.0	2.756	70.0
UR max	1.575	40.0	1.575	40.0
W/*	0.748	19.0	0.906	23.0
CVB				
ZB max	3.504	89.0	3.858	98.0
ZF	3.701	94.0	4.055	103.0
CVC				
ZB max	3.189	81.0	3.622	92.0
ZF	3.386	86.0	3.819	97.0
Kit No.**	52484-07-1		52484-07-1	
-Z1 Kit No.**	52484-07-3		52484-07-3	

NOTES:
 1)* ± .055 in [± 1.4 mm]
 2)** Kit includes flange and cylinder mounting hardware for one end only.

SIZES 32-100 mm (MF1/MF2 PER VDMA 24562)

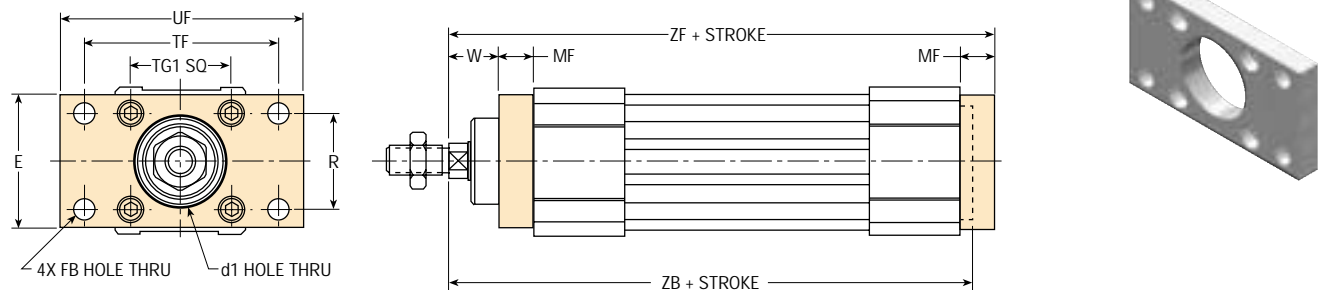

LETTER DIM/ TOLERANCE	BORE SIZE											
	32 mm		40 mm		50 mm		63 mm		80 mm		100 mm	
	in	mm	in	mm	in	mm	in	mm	in	mm	in	mm
d1/H11	1.181	30.0	1.378	35.0	1.575	40.0	1.772	45.0	1.772	45.0	2.165	55.0
FB/H13	.276	7.0	.354	9.0	.354	9.0	.354	9.0	.472	12.0	.551	14.0
TG1	1.280	32.5	1.496	38.0	1.831	46.5	2.224	56.5	2.835	72.0	3.504	89.0
E max	1.969	50.0	2.283	58.0	2.756	70.0	3.346	85.0	4.134	105.0	5.118	130.0
R/JS14	1.260	32.0	1.417	36.0	1.772	45.0	1.969	50.0	2.480	63.0	2.953	75.0
MF	.394	10.0	.394	10.0	.472	12.0	.472	12.0	.630	16.0	.630	16.0
TF/JS14	2.520	64.0	2.835	72.0	3.543	90.0	3.937	100.0	4.961	126.0	5.906	150.0
UF max	3.386	86.0	3.780	96.0	4.528	115.0	5.118	130.0	6.496	165.0	7.362	187.0
Fastener*	M6 x 1 x 20		M6 x 1 x 20		M8 x 1.25 x 20		M8 x 1.25 x 20		M10 x 1.25 x 25		M10 x 1.25 x 25	
W	.630	16.0	.787	20.0	.984	25.0	.984	25.0	1.181	30.0	1.378	35.0
ZB max	4.882	124.0	5.591	142.0	5.866	149.0	6.496	165.0	7.165	182.0	7.795	198.0
ZF	5.118	130.0	5.709	145.0	6.102	155.0	6.693	170.0	7.480	190.0	8.071	205.0
Kit No.*	52484-01-1		52484-02-1		52484-03-1		52484-04-1		52484-05-1		52484-06-1	
-Z1 Kit No.*	52484-01-3		52484-02-3		52484-03-3		52484-04-3		52484-05-3		52484-06-3	

*Kit includes flange and cylinder mounting hardware for one end only.

MOUNTING ACCESSORIES: SERIES CV CYLINDERS

BASE MOUNTING

SIZES 20 & 25 mm (MS3 PER ISO 6432)

LETTER DIM/ TOLERANCE	BORE SIZE			
	20 mm		25 mm	
	in	mm	in	mm
AB/H13	0.260	6.6	0.260	6.6
AO max	0.315	8.0	0.315	8.0
AU max	0.787	20.0	0.787	20.0
NH/**	0.984	25.0	0.984	25.0
SA*	3.898	99.0	4.094	104.0
TG1	1.024	26.0	1.063	27.0
TR/Js14	1.575	40.0	1.575	40.0
US max	2.165	55.0	2.165	55.0
XA*	4.055	103.0	4.409	112.0
XU/^	0.157	4.0	0.315	8.0
Kit No.^	52487-07-1		52487-07-1	
-Z1 Kit No.^	52487-07-3		52487-07-3	

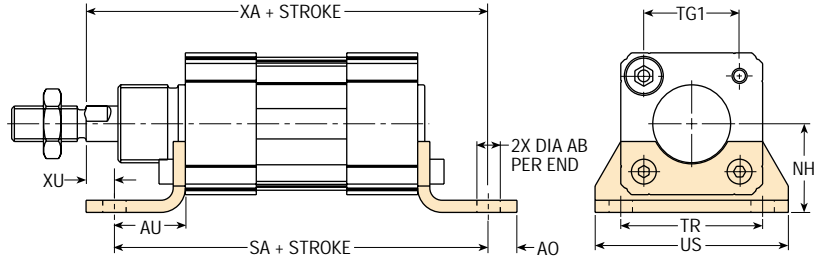

Kit can only be mounted in orientation shown.

NOTES:

- 1)* Dimensions shown are for CVC units. Add to SA dimension .315 in [8 mm] for CVB20 and .236 in [6 mm] for CVB25.
- 2)** ± .008 in [± 0.2 mm]
- 3)^ ± .055 in [± 1.4 mm]
- 4)^ Kit includes bracket and cylinder mounting hardware for one end only.

SIZES 32-100 mm (MS1 PER VDMA 24562)

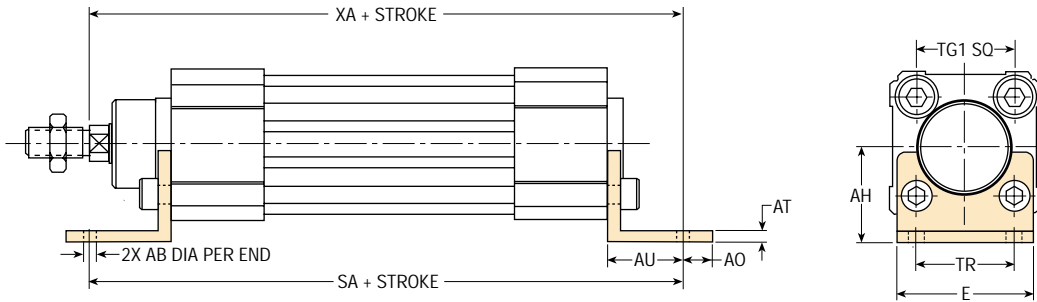

LETTER DIM/ TOLERANCE	BORE SIZE											
	32 mm		40 mm		50 mm		63 mm		80 mm		100 mm	
	in	mm	in	mm	in	mm	in	mm	in	mm	in	mm
AB/H14	.276	7.0	.394	10.0	.394	10.0	.394	10.0	.472	12.0	.571	14.5
TG1	1.280	32.5	1.496	38.0	1.831	46.5	2.224	56.5	2.835	72.0	3.504	89.0
E max	1.969	50.0	2.283	58.0	2.756	70.0	3.346	85.0	4.134	105.0	5.118	130.0
TR	1.260	32.0	1.417	36.0	1.772	45.0	1.969	50.0	2.480	63.0	2.953	75.0
AO max	.433	11.0	.591	15.0	.591	15.0	.591	15.0	.787	20.0	.984	25.0
AU/**	.945	24.0	1.102	28.0	1.260	32.0	1.260	32.0	1.614	41.0	1.614	41.0
AH/JS15	1.260	32.0	1.417	36.0	1.772	45.0	1.969	50.0	2.480	63.0	2.795	71.0
AT	.177	4.5	.177	4.5	.217	5.5	.217	5.5	.256	6.5	.256	6.5
SA	5.591	142.0	6.339	161.0	6.693	170.0	7.283	185.0	8.268	210.0	8.661	220.0
XA	5.669	144.0	6.417	163.0	6.890	175.0	7.480	190.0	8.465	215.0	9.055	230.0
Fastener*	M6 x 1 x 20		M6 x 1 x 20		M8 x 1.25 x 25		M8 x 1.25 x 25		M10 x 1.5 x 25		M10 x 1.5 x 25	
Kit No.*	52487-01-1		52487-02-1		52487-03-1		52487-04-1		52487-05-1		52487-06-1	
-Z1 Kit No.*	52487-01-3		52487-02-3		52487-03-3		52487-04-3		52487-05-3		52487-06-3	

NOTES:

- 1)* Kit includes bracket and cylinder mounting fasteners for one end only.
- 2)** ± .008 in [± 0.2 mm]

MOUNTING ACCESSORIES: SERIES CV CYLINDERS

FASTENER MOUNTING

SIZES 20 & 25 mm (MX1)

SIZES 32-100 mm (MX1 PER ISO 6431)

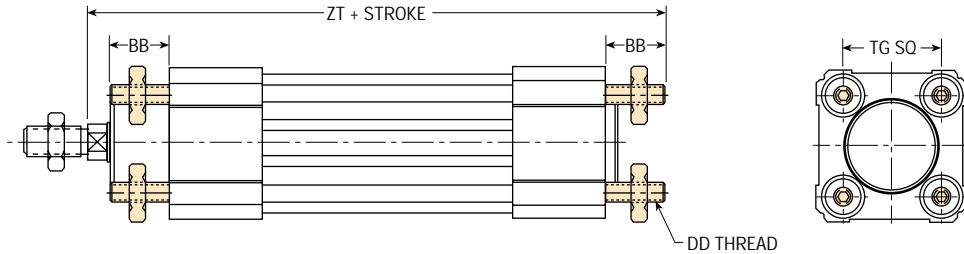

LETTER DIM	BORE SIZE															
	20 mm		25 mm		32 mm		40 mm		50 mm		63 mm		80 mm		100 mm	
	in	mm	in	mm	in	mm	in	mm	in	mm	in	mm	in	mm	in	mm
BB min	0.512	13.0	0.512	13.0	.669	17.0	.669	17.0	.906	23.0	.906	23.0	1.102	28.0	1.102	28.0
DD	M4 x 0.7		M4 x 0.7		M6 x 1.0		M6 x 1.0		M8 x 1.25		M8 x 1.25		M10 x 1.5		M10 x 1.5	
ZT	3.780*	96.0*	4.134*	105.0*	5.394	137.0	5.984	152.0	6.535	166.0	7.126	181.0	7.953	202.0	8.543	217.0
TG	1.024	26.0	1.063	27.0	1.280	32.5	1.496	38.0	1.831	46.5	2.224	56.5	2.835	72.0	3.504	89.0
Kit No.**	63480-04-1		63480-04-1		63480-01-1		63480-01-1		63480-02-1		63480-02-1		63480-03-1		63480-03-1	
-Z1 Kit No.**	63480-04-3		63480-04-3		63480-01-3		63480-01-3		63480-02-3		63480-02-3		63480-03-3		63480-03-3	

NOTES:

1)* Dimensions shown are for CVC units. Add ZT dimension .315 in [8 mm] for CVB20 and .236 in [6 mm] for CVB25.

2)**Kit includes cylinder mounting hardware for one end only.

REAR FORK MOUNTING

SIZES 32-100 mm (MP2 PER VDMA 24562)

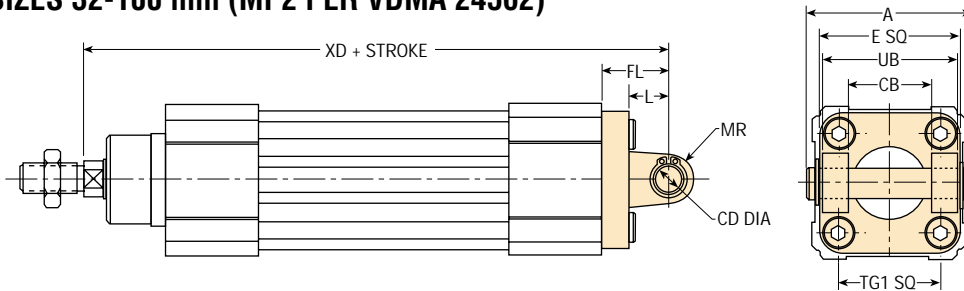

LETTER DIM/TOLERANCE	BORE SIZE											
	32 mm		40 mm		50 mm		63 mm		80 mm		100 mm	
	in	mm	in	mm	in	mm	in	mm	in	mm	in	mm
A max	2.559	65.0	2.835	72.0	3.150	80.0	3.740	95.0	4.528	115.0	5.315	135.0
E max	1.969	50.0	2.283	58.0	2.756	70.0	3.346	85.0	4.134	105.0	5.118	130.0
UB/h14	1.772	45.0	2.047	52.0	2.362	60.0	2.756	70.0	3.543	90.0	4.331	110.0
CB/H14	1.024	26.0	1.102	28.0	1.260	32.0	1.575	40.0	1.969	50.0	2.362	60.0
TG1	1.280	32.5	1.496	38.0	1.831	46.5	2.224	56.5	2.835	72.0	3.504	89.0
FL/*	.866	22.0	.984	25.0	1.063	27.0	1.260	32.0	1.417	36.0	1.614	41.0
L min	.472	12.0	.591	15.0	.591	15.0	.787	20.0	.787	20.0	.984	25.0
CD/H9	.394	10.0	.472	12.0	.472	12.0	.630	16.0	.630	16.0	.787	20.0
MR max	.433	11.0	.512	13.0	.512	13.0	.669	17.0	.669	17.0	.827	21.0
XD	5.591	142.0	6.299	160.0	6.693	170.0	7.480	190.0	8.268	210.0	9.055	230.0
Fastener**	M6 x 1 x 20		M6 x 1 x 20		M8 x 1.25 x 20		M8 x 1.25 x 20		M10 x 1.5 x 25		M10 x 1.5 x 25	
Kit No.**	52485-01-1		52485-02-1		52485-03-1		52485-04-1		52485-05-1		52485-06-1	
-Z1 Kit No.**	52485-01-3		52485-02-3		52485-03-3		52485-04-3		52485-05-3		52485-06-3	

NOTES:

1) * ± .008 in [±0.2 mm] tolerance

2) ** Kit includes rear fork, cylinder mounting fasteners, pivot pin, and pivot pin retainer clips.

3) Mounting is compatible with MP4 male hinge and BMP4 pillow block.

MOUNTING ACCESSORIES: SERIES CV CYLINDERS

REAR MALE HINGE MOUNTING SIZES 20 & 25 mm

LETTER DIM/ TOLERANCE	BORE SIZE			
	20 mm		25 mm	
	in	mm	in	mm
CA	1.181	30.0	1.181	30.0
CK	0.315	8.0	0.315	8.0
EM	0.634	16.1	0.634	16.1
FL min	0.472	12.0	0.472	12.0
G1	0.630	16.0	0.630	16.0
G2	0.787	20.0	0.787	20.0
G3	1.260	32.0	1.260	32.0
H6	0.157	4.0	0.157	4.0
K2	0.949	24.1	0.949	24.1
R1	0.394	10.0	0.394	10.0
XD*	2.795	71.0	2.992	76.0
Fastener	M6		M6	
Kit No.	65778-01-1		65778-01-1	
-Z1 Kit NO.	65778-01-3		65778-01-3	

* Dimensions shown are for CVC units. Add to XD dim
.315 in [8 mm] for CVB20 and .236 in [6 mm] for CVB25.

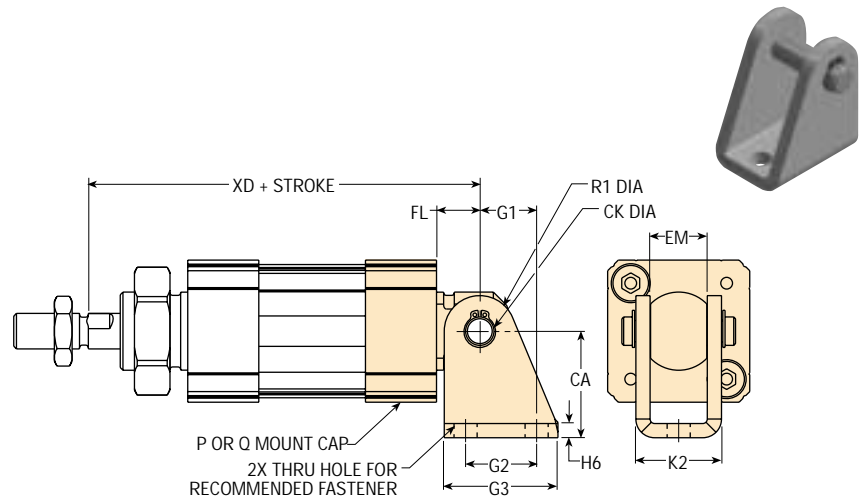

1D

SIZES 32-100 mm (MP4 PER VDMA 24562)

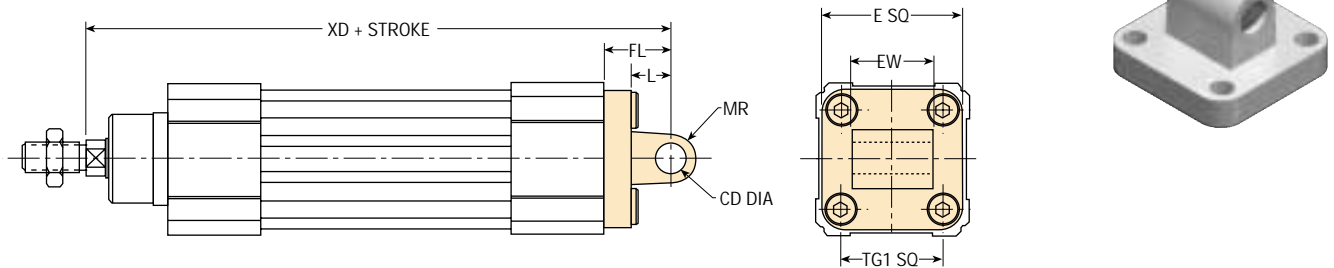

LETTER DIM/ TOLERANCE	BORE SIZE											
	32 mm		40 mm		50 mm		63 mm		80 mm		100 mm	
	in	mm	in	mm	in	mm	in	mm	in	mm	in	mm
E max	1.969	50.0	2.283	58.0	2.756	70.0	3.346	85.0	4.134	105.0	5.118	130.0
EW max	1.024	26.0	1.102	28.0	1.260	32.0	1.575	40.0	1.969	50.0	2.362	60.0
TG1	1.280	32.5	1.496	38.0	1.831	46.5	2.224	56.5	2.835	72.0	3.504	89.0
FL/*	.866	22.0	.984	25.0	1.063	27.0	1.260	32.0	1.417	36.0	1.614	41.0
L min	.472	12.0	.591	15.0	.591	15.0	.787	20.0	.787	20.0	.984	25.0
CD/H9	.394	10.0	.472	12.0	.472	12.0	.630	16.0	.630	16.0	.787	20.0
MR max	.433	11.0	.512	13.0	.512	13.0	.669	17.0	.669	17.0	.827	21.0
XD	5.591	142.0	6.299	160.0	6.693	170.0	7.480	190.0	8.268	210.0	9.055	230.0
Fastener**	M6 x 1 x 20		M6 x 1 x 20		M8 x 1.25 x 20		M8 x 1.25 x 20		M10 x 1.5 x 25		M10 x 1.5 x 25	
Kit No.**	52486-01-1		52486-02-1		52486-03-1		52486-04-1		52486-05-1		52486-06-1	
-Z1 Kit No.**	52486-01-3		52486-02-3		52486-03-3		52486-04-3		52486-05-3		52486-06-3	

NOTES:

- 1) * ± .008 in [±0.2 mm] tolerance
- 2) **Kit includes hinge and cylinder mounting fasteners.
- 3) Rear male hinge is compatible with MP2 mounting.

All dimensions are reference only unless specifically toleranced.

MOUNTING ACCESSORIES: SERIES CV CYLINDERS

PILLOW BLOCK MOUNTING WITH RIGID BEARINGS (BMP4, CETOP RP 107P)

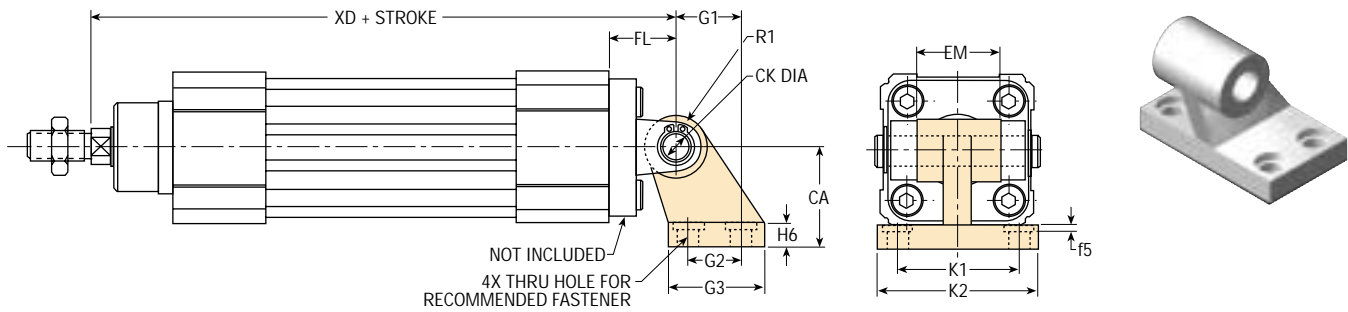

LETTER DIM/ TOLERANCE	BORE SIZE											
	32 mm		40 mm		50 mm		63 mm		80 mm		100 mm	
	in	mm	in	mm	in	mm	in	mm	in	mm	in	mm
CK/H9	.394	10.0	.472	12.0	.472	12.0	.630	16.0	.630	16.0	.787	20.0
K1/JS14	1.496	38.0	1.614	41.0	1.969	50.0	2.047	52.0	2.598	66.0	2.992	76.0
K2 max	2.008	51.0	2.126	54.0	2.559	65.0	2.638	67.0	3.386	86.0	3.780	96.0
G1/JS14	.827	21.0	.945	24.0	1.299	33.0	1.457	37.0	1.850	47.0	2.165	55.0
f5 max	.063	1.6	.063	1.6	.063	1.6	.063	1.6	.098	2.5	.098	2.5
G2	.709	18.0	.866	22.0	1.181	30.0	1.378	35.0	1.575	40.0	1.969	50.0
EM max	1.016	25.8	1.094	27.8	1.252	31.8	1.567	39.8	1.961	49.8	2.354	59.8
G3 max	1.220	31.0	1.378	35.0	1.772	45.0	1.969	50.0	2.362	60.0	2.756	70.0
CA/JS15	1.260	32.0	1.417	36.0	1.772	45.0	1.969	50.0	2.480	63.0	2.795	71.0
H6	.315	8.0	.394	10.0	.472	12.0	.472	12.0	.551	14.0	.591	15.0
R1 max	.394	10.0	.433	11.0	.512	13.0	.591	15.0	.591	15.0	.748	19.0
FL	.866	22.0	.984	25.0	1.063	27.0	1.260	32.0	1.417	36.0	1.614	41.0
XD	5.591	142.0	6.299	160.0	6.693	170.0	7.480	190.0	8.268	210.0	9.055	230.0
Fastener	M6	M6	M6	M6	M8	M8	M8	M8	M10	M10	M10	M10
Kit No.*	62818-001-00		62818-002-00		62818-003-00		62818-004-00		62818-005-00		62818-006-00	

NOTES:

- 1) Pillow block is compatible with MP2 rear fork.
- 2) *Kit includes pillow block only (no fasteners or pivot pin).

REAR FORK MOUNTING FOR SPHERICAL BEARING (PHD MSB2 PER VDMA 24562)

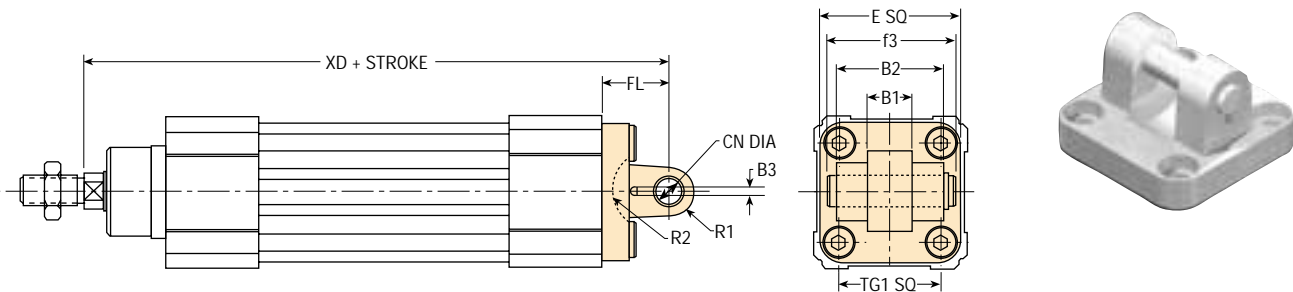

LETTER DIM/ TOLERANCE	BORE SIZE											
	32 mm		40 mm		50 mm		63 mm		80 mm		100 mm	
	in	mm	in	mm	in	mm	in	mm	in	mm	in	mm
E max	1.969	50.0	2.283	58.0	2.756	70.0	3.346	85.0	4.134	105.0	5.118	130.0
B2/d12	1.339	34.0	1.575	40.0	1.772	45.0	2.008	51.0	2.559	65.0	2.953	75.0
B1/H14	.551	14.0	.630	16.0	.827	21.0	.827	21.0	.984	25.0	.984	25.0
TG1	1.280	32.5	1.496	38.0	1.831	46.5	2.224	56.5	2.835	72.0	3.504	89.0
B3/*	.130	3.3	.169	4.3	.169	4.3	.169	4.3	.169	4.3	.248	6.3
R2 min	.669	17.0	.787	20.0	.866	22.0	.984	25.0	1.181	30.0	1.260	32.0
f3	1.811	46.0	2.087	53.0	2.283	58.0	2.598	66.0	3.150	80.0	3.543	90.0
FL/*	.866	22.0	.984	25.0	1.063	27.0	1.260	32.0	1.417	36.0	1.614	41.0
CN/F7	.394	10.0	.472	12.0	.630	16.0	.630	16.0	.787	20.0	.787	20.0
R1 max	.433	11.0	.512	13.0	.709	18.0	.709	18.0	.866	22.0	.866	22.0
XD	5.591	142.0	6.299	160.0	6.693	170.0	7.480	190.0	8.268	210.0	9.055	230.0
Fastener**	M6 x 1 x 20		M6 x 1 x 20		M8 x 1.25 x 20		M8 x 1.25 x 20		M10 x 1.5 x 25		M10 x 1.5 x 25	
Kit No.**	52489-01-1		52489-02-1		52489-03-1		52489-04-1		52489-05-1		52489-06-1	
-Z1 Kit No.**	52489-01-3		52489-02-3		52489-03-3		52489-04-3		52489-05-3		52489-06-3	

NOTES:

- 1) *± .008 in [±0.2 mm] tolerance
- 2) **Kit includes rear fork, cylinder mounting fasteners, pivot pin, and pivot pin retainer.
- 3) Rear fork is compatible with BSB1 pillow block, rod eye, and MSB1 rear male hinge with spherical bearings per DIN 648 K.

MOUNTING ACCESSORIES: SERIES CV CYLINDERS

REAR MALE HINGE MOUNTING WITH SPHERICAL BEARING (PHD MSB1)

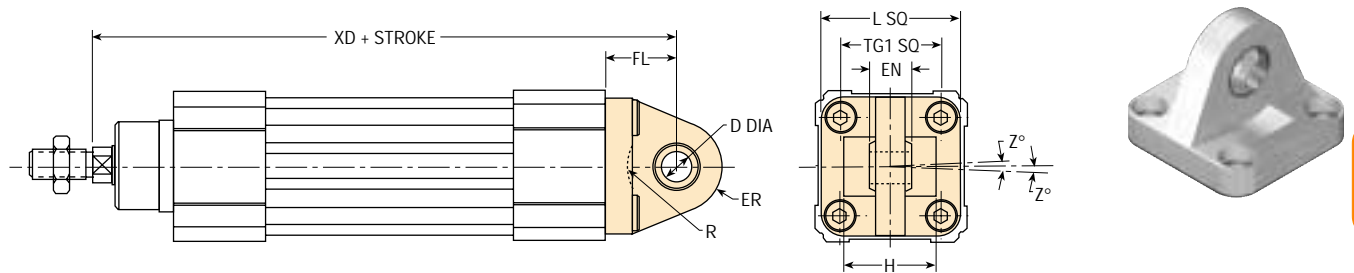

LETTER DIM/ TOLERANCE	BORE SIZE											
	32 mm		40 mm		50 mm		63 mm		80 mm		100 mm	
	in	mm	in	mm	in	mm	in	mm	in	mm	in	mm
TG1	1.280	32.5	1.496	38.0	1.831	46.5	2.224	56.5	2.835	72.0	3.504	89.0
FL/JS15	.866	22.0	.984	25.0	1.063	27.0	1.260	32.0	1.417	36.0	1.614	41.0
D/H7	.394	10.0	.472	12.0	.630	16.0	.630	16.0	.787	20.0	.787	20.0
EN/*	.551	14.0	.630	16.0	.827	21.0	.827	21.0	.984	25.0	.984	25.0
ER max	.591	15.0	.709	18.0	.787	20.0	.906	23.0	1.063	27.0	1.181	30.0
L max	1.969	50.0	2.283	58.0	2.756	70.0	3.346	85.0	4.134	105.0	5.118	130.0
Z°	4°	4°	4°	4°	4°	4°	4°	4°	4°	4°	4°	4°
H	—	—	—	—	2.008	51.0	—	—	—	—	—	—
R	—	—	—	—	.748	19.0	—	—	—	—	—	—
XD	5.591	142.0	6.299	160.0	6.693	170.0	7.480	190.0	8.268	210.0	9.055	230.0
Fastener**	M6 x 1 x 20		M6 x 1 x 20		M8 x 1.25 x 20		M8 x 1.25 x 20		M10 x 1.5 x 25		M10 x 1.5 x 25	
Kit No.**	52488-01-1		52488-02-1		52488-03-1		52488-04-1		52488-05-1		52488-06-1	
-Z1 Kit No.**	52488-01-3		52488-02-3		52488-03-3		52488-04-3		52488-05-3		52488-06-3	

NOTES:

- 1) *.000/-0.004 in [+0.0/-0.1 mm] tolerance
- 2) **Kit includes hinge and cylinder mounting fasteners.
- 3) Rear male hinge is compatible with MSB2 rear fork for spherical bearing.

PILLOW BLOCK MOUNTING WITH SPHERICAL BEARING (PHD BSB1 PER VDMA 24562)

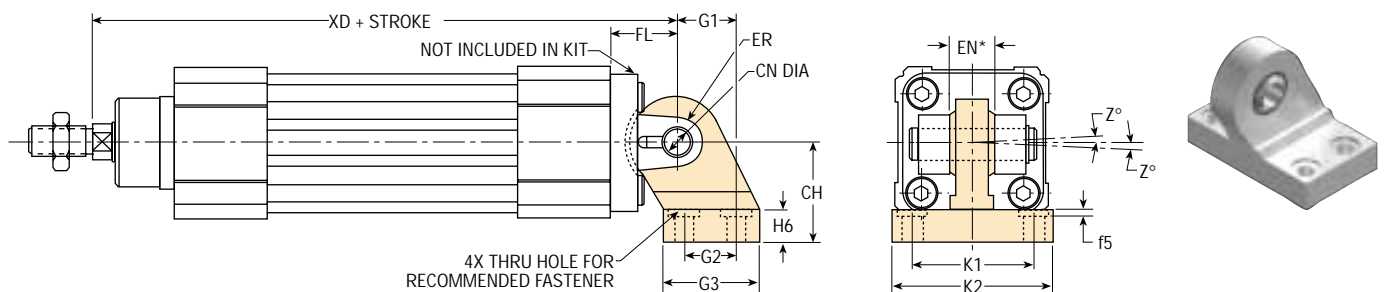

LETTER DIM/ TOLERANCE	BORE SIZE											
	32 mm		40 mm		50 mm		63 mm		80 mm		100 mm	
	in	mm	in	mm	in	mm	in	mm	in	mm	in	mm
CN/H7	.394	10.0	.472	12.0	.630	16.0	.630	16.0	.787	20.0	.787	20.0
K1/JS 14	1.496	38.0	1.614	41.0	1.969	50.0	2.047	52.0	2.598	66.0	2.992	76.0
K2 max	2.008	51.0	2.126	54.0	2.559	65.0	2.638	67.0	3.386	86.0	3.780	96.0
G1/JS14	.827	21.0	.945	24.0	1.299	33.0	1.457	37.0	1.850	47.0	2.165	55.0
f5 max	.063	1.6	.063	1.6	.063	1.6	.063	1.6	.098	2.5	.098	2.5
G2/JS14	.709	18.0	.866	22.0	1.181	30.0	1.378	35.0	1.575	40.0	1.969	50.0
EN/*	.551	14.0	.630	16.0	.827	21.0	.827	21.0	.984	25.0	.984	25.0
G3 max	1.220	31.0	1.378	35.0	1.772	45.0	1.969	50.0	2.362	60.0	2.756	70.0
CH/JS15	1.260	32.0	1.417	36.0	1.772	45.0	1.969	50.0	2.480	63.0	2.795	71.0
H6	.394	10.0	.394	10.0	.472	12.0	.472	12.0	.551	14.0	.591	15.0
ER max	.630	16.0	.709	18.0	.827	21.0	.906	23.0	1.102	28.0	1.181	30.0
FL	.866	22.0	.984	25.0	1.063	27.0	1.260	32.0	1.417	36.0	1.614	41.0
XD	5.591	142.0	6.299	160.0	6.693	170.0	7.480	190.0	8.268	210.0	9.055	230.0
Z°	4°	4°	4°	4°	4°	4°	4°	4°	4°	4°	4°	4°
Fastener	M6	M6	M6	M6	M8	M8	M8	M8	M10	M10	M10	M10
Kit No.**	62822-001-00		62822-002-00		62822-003-00		62822-004-00		62822-005-00		62822-006-00	

NOTES:

- 1) Pillow block is compatible with MSB2 rear fork for spherical bearing.
- 2) *.000/-0.004 in [+0.0/-0.1 mm] tolerance
- 3) **Kits include pillow block only (no fasteners or pivot pin).
- 4) Not available in -Z1.

All dimensions are reference only unless specifically tolerated.

MOUNTING ACCESSORIES: SERIES CV CYLINDERS

PIVOT PINS

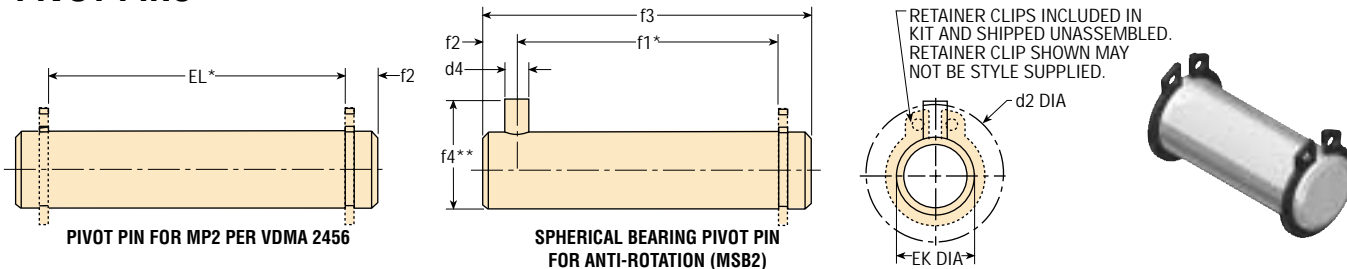

LETTER DIM/ TOLERANCE	BORE SIZE											
	32 mm		40 mm		50 mm		63 mm		80 mm		100 mm	
	in	mm	in	mm	in	mm	in	mm	in	mm	in	mm
MP2 PIVOT PIN												
d2 max	.906	23.0	.984	25.0	.984	25.0	1.260	32.0	1.260	32.0	1.575	40.0
EK/e8	.394	10.0	.472	12.0	.472	12.0	.630	16.0	.630	16.0	.787	20.0
EL/*	1.811	46.0	2.087	53.0	2.402	61.0	2.795	71.0	3.583	91.0	4.370	111.0
f2 max	.335	8.5	.335	8.5	.335	8.5	.433	11.0	.433	11.0	.433	11.0
Kit	52490-01-1		52490-02-1		52490-03-1		52490-04-1		52490-05-1		52490-06-1	
-Z1 Kit	52490-01-3		52490-02-3		52490-03-3		52490-04-3		52490-05-3		52490-06-3	
MSB2 PIVOT PIN												
d2 max	.906	23.0	.984	25.0	.984	25.0	1.260	32.0	1.260	32.0	1.575	40.0
d4/H12	.118	3.0	.157	4.0	.157	4.0	.157	4.0	.157	4.0	.157	4.0
EK/h9	.394	10.0	.472	12.0	.630	16.0	.630	16.0	.787	20.0	.787	20.0
f1/*	1.280	32.5	1.496	38.0	1.693	43.0	1.929	49.0	2.480	63.0	2.874	73.0
f2 max	.177	4.5	.236	6.0	.236	6.0	.236	6.0	.236	6.0	.236	6.0
f3 max	1.811	46.0	2.087	53.0	2.283	58.0	2.598	66.0	3.150	80.0	3.543	90.0
f4/**	.551	14.0	.630	16.0	.787	20.0	.787	20.0	.945	24.0	.945	24.0
Kit No.	52491-01-1		52491-02-1		52491-03-1		52491-04-1		52491-05-1		52491-06-1	
-Z1 Kit No.	52491-01-3		52491-02-3		52491-03-3		52491-04-3		52491-05-3		52491-06-3	

NOTES:

- 1) *+.08/-0.000 in [+2.0/-0.0 mm] tolerance
- 2) **+.000/-0.016 in [+0.0/-0.4 mm] tolerance

ROD EYE MOUNTING WITH SPHERICAL BEARING SIZES 20-100 mm (DIN 8139)

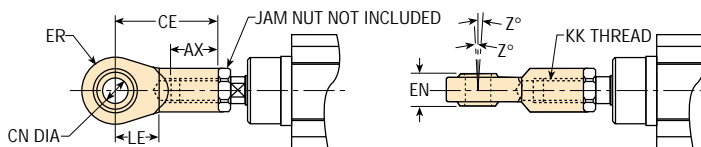

LETTER DIM/ TOLERANCE	BORE SIZE															
	20 mm		25 mm		32 mm		40 mm		50 mm		63 mm		80 mm		100 mm	
	in	mm	in	mm	in	mm	in	mm	in	mm	in	mm	in	mm	in	mm
AX min	.630	16.0	.787	20.0	.787	20.0	.866	22.0	1.102	28.0	1.102	28.0	1.299	33.0	1.299	33.0
CE	1.417	36.0	1.693	43.0	1.693	43.0	1.969	50.0	2.520	64.0	2.520	64.0	3.031	77.0	3.031	77.0
CN/H9	.315	8.0	.394	10.0	.394	10.0	.472	12.0	.630	16.0	.630	16.0	.787	20.0	.787	20.0
EN/h12	.472	12.0	.551	14.0	.551	14.0	.630	16.0	.827	21.0	.827	21.0	.984	25.0	.984	25.0
ER max	.472	12.0	.551	14.0	.551	14.0	.630	16.0	.827	21.0	.827	21.0	.984	25.0	.984	25.0
KK	M8		M10 x 1.25		M10 x 1.25		M12 x 1.25		M16 x 1.5		M16 x 1.5		M20 x 1.5		M20 x 1.5	
LE min	.512	13.0	.591	15.0	.591	15.0	.669	17.0	.906	23.0	.906	23.0	1.063	27.0	1.063	27.0
Z°	4°		4°		4°	4°	4°	4°	4°	4°	4°	4°	4°	4°	4°	4°
Kit No.*	52493-05-1		52493-01-1		52493-01-1		52493-02-1		52493-03-1		52493-03-1		52493-04-1		52493-04-1	

NOTES:

- 1) 32-100 mm sizes compatible with MSB2 rear fork for spherical bearing.
- 2) *Kits do not include jam nut.
- 3) Not available in -Z1

MOUNTING ACCESSORIES: SERIES CV CYLINDERS

ROD CLEVIS MOUNTING SIZES 20-100 mm (DIN 8140)

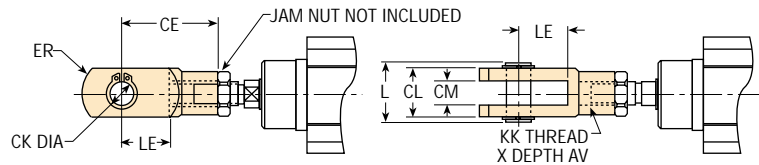

LETTER DIM/ TOLERANCE	BORE SIZE															
	20 mm		25 mm		32 mm		40 mm		50 mm		63 mm		80 mm		100 mm	
	in	mm	in	mm	in	mm	in	mm	in	mm	in	mm	in	mm	in	mm
AV min	0.630	16.0	0.787	20.0	.787	20.0	.866	22.0	1.102	28.0	1.102	28.0	1.299	33.0	1.299	33.0
CE	1.260	32.0	1.575	40.0	1.575	40.0	1.890	48.0	2.520	64.0	2.520	64.0	3.150	80.0	3.150	80.0
CK/H9	0.316	8.02	0.394	10.02	.394	10.0	.472	12.0	.630	16.0	.630	16.0	.787	20.0	.787	20.0
CL max	0.630	16.0	0.787	20.0	.787	20.0	.945	24.0	1.260	32.0	1.260	32.0	1.575	40.0	1.575	40.0
CM min	0.315	8.0	0.394	10.0	.394	10.0	.472	12.0	.630	16.0	.630	16.0	.787	20.0	.787	20.0
ER max	0.512	13.0	0.630	16.0	.630	16.0	.748	19.0	.984	25.0	.984	25.0	1.260	32.0	1.260	32.0
KK	M8 x 1.25		M10 x 1.25		M10 x 1.25		M12 x 1.25		M16 x 1.5		M16 x 1.5		M20 x 1.5		M20 x 1.5	
L	0.827	21.0	0.984	25.0	.984	25.0	1.181	30.0	1.535	39.0	1.535	39.0	1.890	48.0	1.890	48.0
LE min	0.630	16.0	0.787	20.0	.787	20.0	.945	24.0	1.260	32.0	1.260	32.0	1.575	40.0	1.575	40.0
Kit No.*	52492-05-1		52492-01-1		52492-01-1		52492-02-1		52492-03-1		52492-03-1		52492-04-1		52492-04-1	
-Z1 Kit No.*	52492-05-3		52492-01-3		52492-01-3		52492-02-3		52492-03-3		52492-03-3		52492-04-3		52492-04-3	

NOTES:

- *Kit includes clevis, pivot pin and pivot pin retainers. Jam nut is not included.
- Pivot pin retainers shown may not be style supplied.

PIVOT PIN ROD CLEVIS SIZES 32-100 mm (DIN 8140)

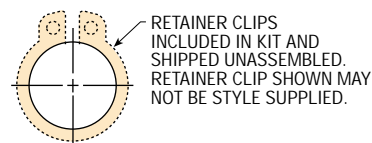
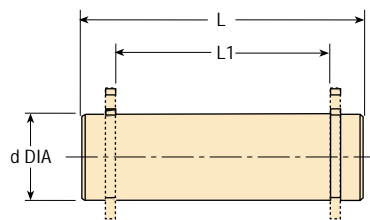

LETTER DIM	BORE SIZE											
	32 mm		40 mm		50 mm		63 mm		80 mm		100 mm	
	in	mm	in	mm	in	mm	in	mm	in	mm	in	mm
d	.394	10.0	.472	12.0	.630	16.0	.630	16.0	.787	20.0	.787	20.0
L	.984	25.0	1.181	30.0	1.535	39.0	1.535	39.0	1.890	48.0	1.890	48.0
L1	.791	20.1	.949	24.1	1.264	32.1	1.264	32.1	1.579	40.1	1.579	40.1
Kit No.	63463-01-1		63463-02-1		63463-03-1		63463-03-1		63463-04-1		63463-04-1	
-Z1 Kit No.	63463-01-3		63463-02-3		63463-03-3		63463-03-3		63463-04-3		63463-04-3	

All dimensions are reference only unless specifically tolerated.

APPLICATION EXAMPLES: SERIES CV CYLINDERS

SIMPLIFY AND ACCELERATE LOCTITE PROCESS

For this application, three PHD components are used to loctite a bearing race to the stator housing of an electric motor. A PHD Series T Slide suspended by 2 connected standard PHD stanchions, provides the linear motion necessary to get the application needle down to the stator housing. A CV Cylinder mounted on the side of the slide stops the flow of loctite when not needed by simply pinching the tube within the slide tooling plate. Each stator housing is revolved into position on a conveyor where a Series 2000 Multi-Motion Actuator with a tooling plate attached extends upward, metal pins on the tooling plate hold the stator in place, and the multi-motion actuator turns 360° covering the entire radius of the bearing race and housing seam with loctite. The multi-motion then retract and the next housing is moved into place. This automated process takes 3.5 seconds.

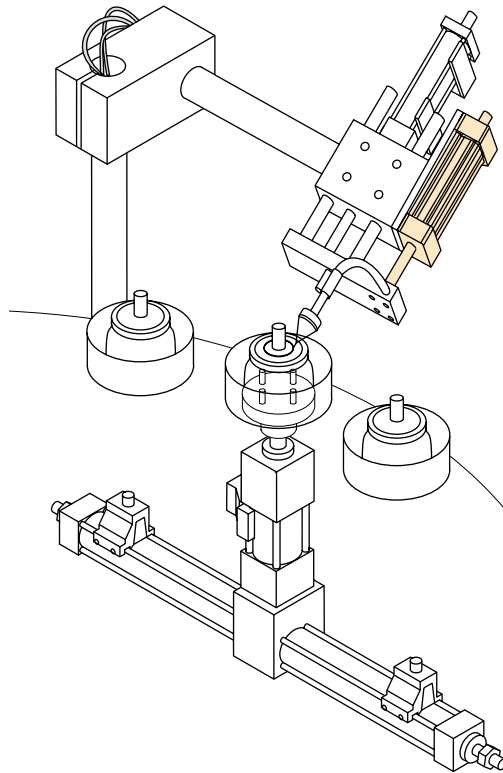

CYLINDER WITH RODLOK® HOLDS DEVICE DURING LOADING PROCESS

In this application a PHD Series CV double rod end cylinder is used on a crankshaft polishing machine. The cylinder with Rodlok® raises and holds the polishing belt device during the loading process. Once loaded, the Rodlok® releases its hold and the cylinder lowers the polishing device. Six of these devices are combined on this machine.

